



BSI Standards Publication

**Metal valves for use in flanged pipe systems —
Face-to-face and centre-to-face dimensions**

INTERNATIONAL STANDARD

ISO
5752

Third edition
2021-06

Metal valves for use in flanged pipe systems — Face-to-face and centre-to- face dimensions

*Appareils de robinetterie métalliques utilisés dans les tuyauteries à
brides — Dimensions face-à-face et face-à-axe*



Reference number
ISO 5752:2021(E)

© ISO 2021



COPYRIGHT PROTECTED DOCUMENT

© ISO 2021

All rights reserved. Unless otherwise specified, or required in the context of its implementation, no part of this publication may be reproduced or utilized otherwise in any form or by any means, electronic or mechanical, including photocopying, or posting on the internet or an intranet, without prior written permission. Permission can be requested from either ISO at the address below or ISO's member body in the country of the requester.

ISO copyright office
CP 401 • Ch. de Blandonnet 8
CH-1214 Vernier, Geneva
Phone: +41 22 749 01 11
Email: copyright@iso.org
Website: www.iso.org

Published in Switzerland

Contents		Page
Foreword		iv
Introduction		v
1 Scope		1
2 Normative references		1
3 Terms and definitions		1
4 Dimensions and tolerances		2
Annex A (normative) Additional length for valves with ring joint flange		27
Annex B (informative) Relationship between DN and NPS		29
Annex C (informative) Origin of basic series		30
Bibliography		34

Foreword

ISO (the International Organization for Standardization) is a worldwide federation of national standards bodies (ISO member bodies). The work of preparing International Standards is normally carried out through ISO technical committees. Each member body interested in a subject for which a technical committee has been established has the right to be represented on that committee. International organizations, governmental and non-governmental, in liaison with ISO, also take part in the work. ISO collaborates closely with the International Electrotechnical Commission (IEC) on all matters of electrotechnical standardization.

The procedures used to develop this document and those intended for its further maintenance are described in the ISO/IEC Directives, Part 1. In particular, the different approval criteria needed for the different types of ISO documents should be noted. This document was drafted in accordance with the editorial rules of the ISO/IEC Directives, Part 2 (see www.iso.org/directives).

Attention is drawn to the possibility that some of the elements of this document may be the subject of patent rights. ISO shall not be held responsible for identifying any or all such patent rights. Details of any patent rights identified during the development of the document will be in the Introduction and/or on the ISO list of patent declarations received (see www.iso.org/patents).

Any trade name used in this document is information given for the convenience of users and does not constitute an endorsement.

For an explanation of the voluntary nature of standards, the meaning of ISO specific terms and expressions related to conformity assessment, as well as information about ISO's adherence to the World Trade Organization (WTO) principles in the Technical Barriers to Trade (TBT), see www.iso.org/iso/foreword.html.

This document was prepared by Technical Committee ISO/TC 153, *Valves*.

This third edition cancels and replaces the second edition (ISO 5752:1982), which has been technically revised.

The main changes compared to the previous edition are as follows:

- extension to PN 63; PN 100; PN 160; PN 250; PN 320; PN 400; deletion of PN 1; PN 1,6; PN 4;
- extension to Class 900; Class 1 500; Class 2 500;
- addition of DN 1 050; deletion of DN 550;
- deletion of Table 1 (Isobaric) and Table 10 (copper alloy);
- update of the basic series in [Table 1](#);
- update of the face-to-face and centre-to-face dimensions in [Tables 2 to 19](#);
- addition of an informative [Annex B](#) giving the relationship between DN and NPS;
- addition of an informative [Annex C](#) giving the origin of each basic series.

Any feedback or questions on this document should be directed to the user's national standards body. A complete listing of these bodies can be found at www.iso.org/members.html.

Introduction

The aim of this document is to establish face-to-face and centre-to-face dimensions for metal valves to permit a degree of dimensional interchangeability. They are intended to be used in valve product standards.

Although the tables of face-to-face dimensions in this document represent a considerable rationalization of international practices, it has not been possible to reduce these to a single series of dimensions for the various types of valves. Alternatives have been included. For convenience these have been called short, medium and long, but these terms are not used in a descriptive sense.

The pressure/temperature ratings for the different types of valves are those to be specified for the type of valves and materials used.

The principle of establishing dimensions in this document is that, first, there exists an ISO industrial valve standard covering that product, in its size and pressure rating, and second, certain valve types are of significant international demand and their use justifies inclusion in this document.

Metal valves for use in flanged pipe systems — Face-to-face and centre-to-face dimensions

1 Scope

This document specifies the basic series of face-to-face (FTF) and centre-to-face (CTF) dimensions for two-way metal valves of the gate, globe, diaphragm, ball, plug, butterfly design types used as isolating and check valves in flanged pipe systems. Each basic series of face-to-face and centre-to-face dimensions can be used as required with flanges of mating dimensions conforming to the equivalent EN or ASME flange series.

This document covers valves with the following PN, Class, DN and NPS values:

- PN 2,5; PN 6; PN 10; PN 16; PN 25; PN 40; PN 63; PN 100; PN 160; PN 250; PN 320; PN 400;
- Class 125; Class 150; Class 250; Class 300; Class 600; Class 900; Class 1 500; Class 2 500;
- DN 10; DN 15; DN 20; DN 25; DN 32; DN 40; DN 50; DN 65; DN 80; DN 100; DN 125; DN 150; DN 200; DN 250; DN 300; DN 350; DN 400; DN 450; DN 500; DN 600; DN 650; DN 700; DN 750; DN 800; DN 900; DN 1 000; DN 1 050; DN 1 200; DN 1 400; DN 1 600; DN 1 800; DN 2 000;
- corresponding to nominal sizes NPS: $\frac{3}{8}$; $\frac{1}{2}$; $\frac{3}{4}$; 1; 1 $\frac{1}{4}$; 1 $\frac{1}{2}$; 2; 2 $\frac{1}{2}$; 3; 4; 5; 6; 8; 10; 12; 14; 16; 18; 20; 24; 26; 28; 30; 32; 36; 40; 42; 48; 56; 64; 72; 80.

NOTE See [Annex B](#) for the relationship between DN and NPS.

2 Normative references

There are no normative references in this document.

3 Terms and definitions

For the purposes of this document, the following terms and definitions apply.

ISO and IEC maintain terminological databases for use in standardization at the following addresses:

- ISO Online browsing platform: available at <https://www.iso.org/obp>
- IEC Electropedia: available at <http://www.electropedia.org/>

3.1

DN

NPS

nominal size

alphanumeric designation of size for components of a pipework system, which is used for reference purposes, comprising the letters DN or NPS followed by a dimensionless number which is indirectly related to the physical size, (in millimetres for DN and in inches for NPS), of the bore or outside diameter of the end connections

Note 1 to entry: The number following DN or NPS does not represent a measurable value and is not used for calculation purposes except where specified in a product standard.

[SOURCE: ISO 6708:1995, 2.1, modified — The terms "nominal size" and "NPS" have been added, "NPS" has been integrated into the definition and the Note 2 to entry has been deleted.]

3.2

PN

Class

nominal pressure

numerical designation relating to pressure that is a convenient rounded number for reference purposes, and which comprises the letters "PN" or "Class" followed by the appropriate reference number

Note 1 to entry: It is intended that all equipment of the same *nominal size* (*DN* or *NPS*) ([3.1](#)) designated by the same PN number or Class number shall have compatible mating dimensions.

Note 2 to entry: The maximum allowable pressure depends on materials, design and working temperature, and is to be selected from the tables of pressure/temperature ratings given in the appropriate standards.

[SOURCE: ISO 7268:1983, Clause 2, modified — The terms "nominal pressure" and "Class" have been added, and "Class" has been integrated into the definition.]

3.3

face-to-face dimension

FTF

<straight pattern valves> distance between the two planes perpendicular to the valve axis located at the extremities of the body end ports

Note 1 to entry: Dimensions are expressed in millimetres.

Note 2 to entry: See [Figures 1](#) to [5](#) and [Figure A.1](#).

3.4

centre-to-face dimension

CTF

<angle pattern valves> distance, between the plane located at the extremity of either body end port and perpendicular to its axis and the other body end port axis

Note 1 to entry: Dimensions are expressed in millimetres.

Note 2 to entry: See [Figures 1](#) to [5](#) and [Figure A.1](#).

4 Dimensions and tolerances

The basic series of FTF and CTF dimensions, expressed in millimetres, shall be as given in [Table 1](#).

[Table 1](#) is a summary of the dimensions in [Tables 2](#) to [19](#) giving the origin of each series and should be referred to when considering valve types not covered by this document. Each particular column does not necessarily include all the values of the relevant basic series. See [Annex C](#) for information as to the origin of each basic series.

[Tables 17](#) and [18](#) cover butterfly check or wafer check valves which are retained in the piping by bolting that spans the two adjacent flanges, however these valves may alternately be furnished with full end flanges. Check valves shown as 'long pattern' shall be furnished with full end flanges only.

The face-to-face and centre-to-face dimensions, as appropriate for the types of valves covered by this document, shall be in accordance with [Tables 2](#) to [19](#), and the tolerances shall be in accordance with [Tables 20](#) and [21](#). [Annex A](#) includes additional information on face-to-face and centre-to-face dimensions where ring joint facing is used and shall be followed.

Tolerances on FTF and CTF dimensions as shown in [Figure 1](#) are given in [Table 20](#). Both tolerances shall be fulfilled.

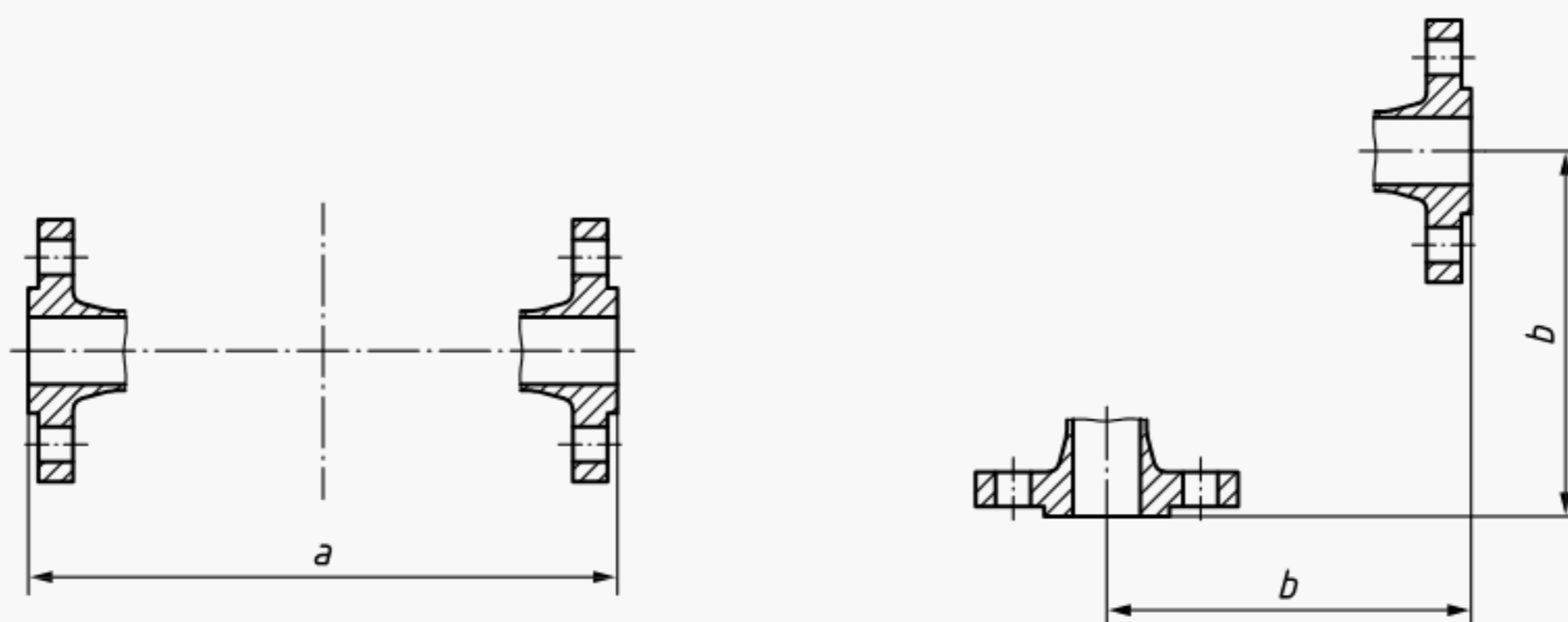

Key

- a* face-to-face (FTF)
- b* centre-to-face (CTF)

Figure 1 — Face to face and centre to face dimensions

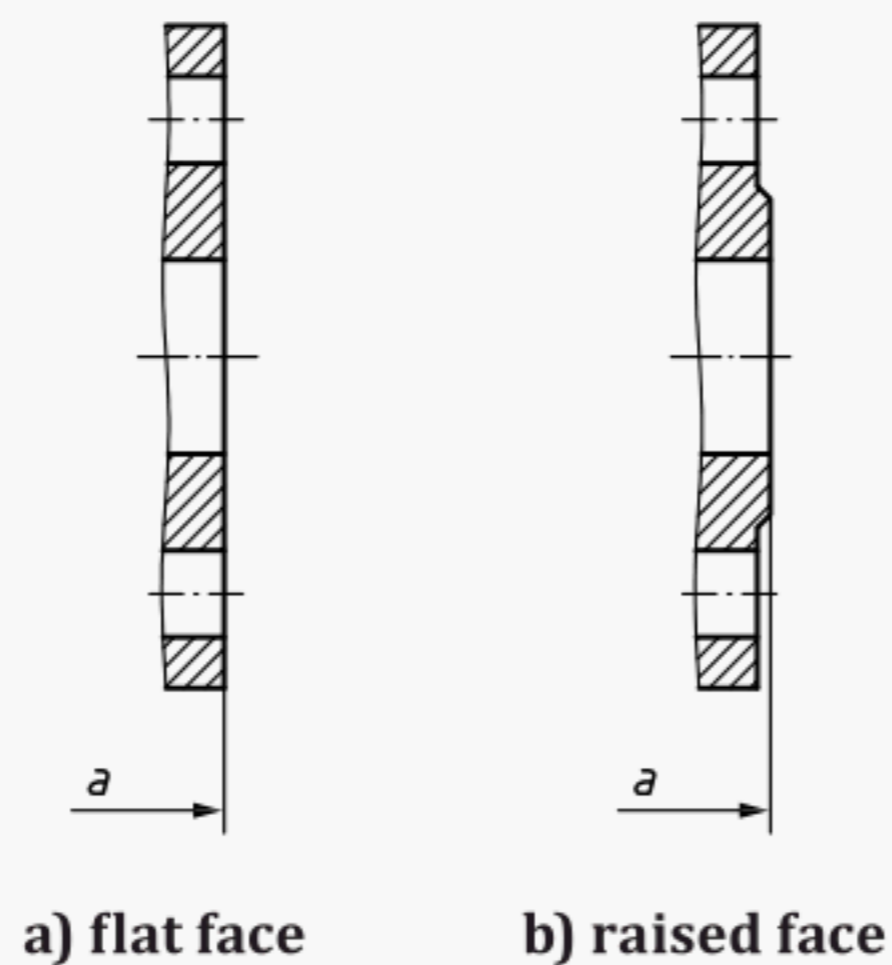

Key

- a* face-to-face (FTF)

Figure 2 — Flanged valves PN and Class designated (flat and raised faces)

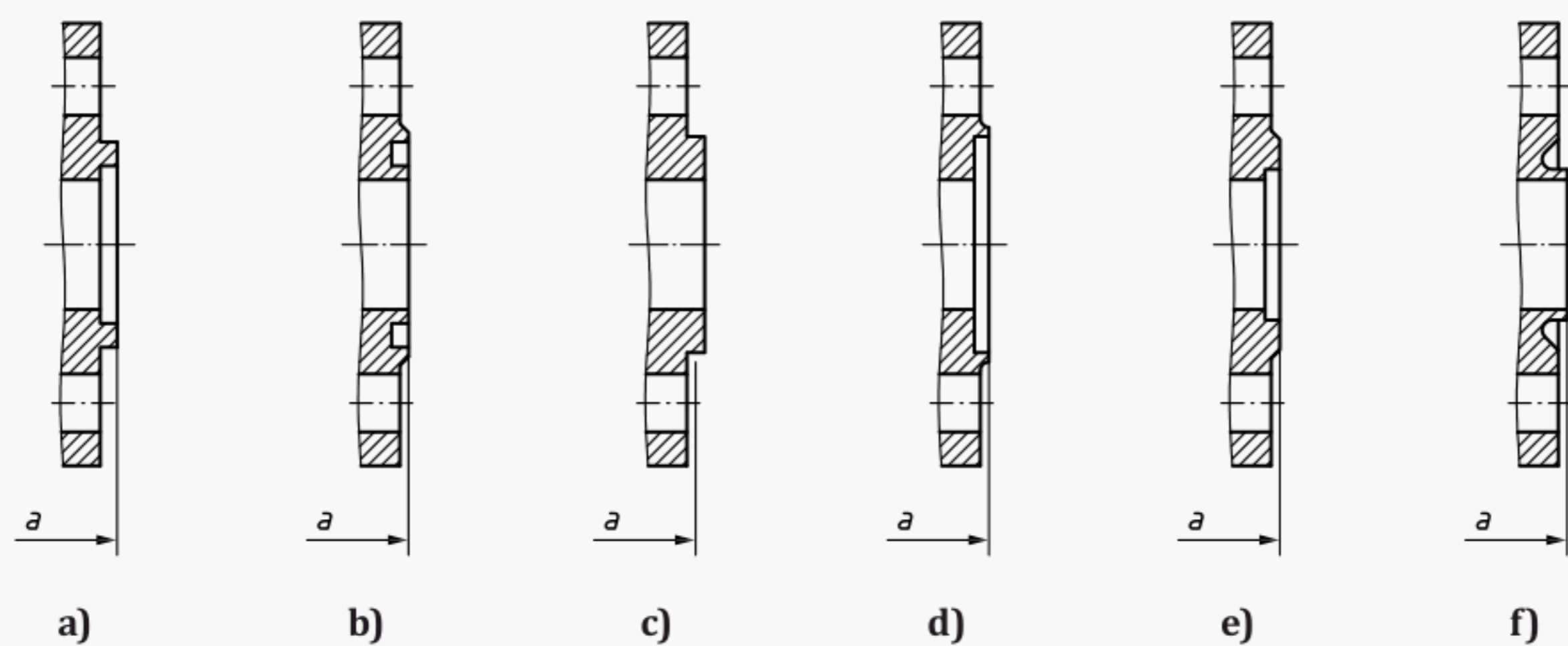

Key

a face-to-face (FTF)

Figure 3 — Flanged valves PN designated (other types)

	Class 150 and Class 300	Class 600 and above
a) Large or small male face	$b = a + 2e$ $c = a + e$	$b = a$ $c = a$
b) Large or small female face	$b = a + 2e$ $c = a + e$	$b = a - 2e$ $c = a - e$
c) Large or small tongue	$b = a + 2e$ $c = a + e$	$b = a$ $c = a$

	Class 150 and Class 300	Class 600 and above
d) Large or small groove	<p>$b = a + 2e$ $c = a + e$ e a</p>	<p>a $b = a - 2e$ $c = a - e$ e</p>

Key

a for dimensions, see [Tables 2 to 19](#)

b face-to-face (FTF)

c centre-to-face (CTF)

e height

NOTE For height *e*, see appropriate flange standard.

Figure 4 — Flanged valves Class designated (other types)

End flange seating surfaces shall be parallel or perpendicular. Tolerances “*c*” on parallel or perpendicular surfaces as shown in [Figure 5](#) are given in [Table 21](#).

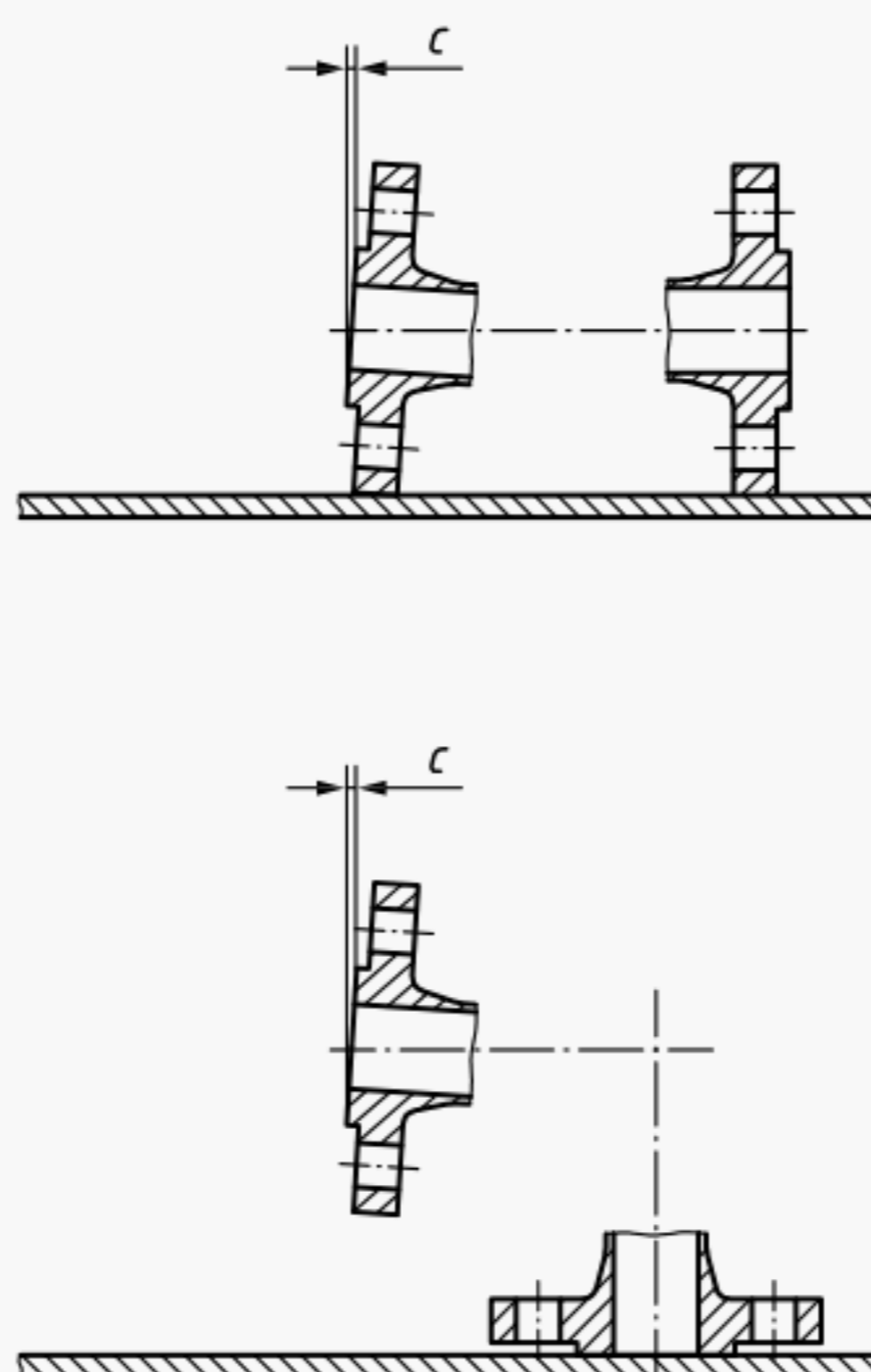

Figure 5 — Tolerances on parallelism and perpendicularity

Table 1 — Dimensions of basic series (1-24)

Dimensions in millimetres

Nominal size		Basic series																				DN	
DN	NPS	1	2	3	4	5	7	8 ^a	9 ^a	10	11 ^a	12	13	14	15	16	17	18	19	20	21	24 ^a	DN
10	3/8	130	210	102	—	—	108	90	105	102	51	130	—	115	—	—	—	80	—	—	—	—	10
15	1/2	130	210	108	140	165	108	90	105	108	57	130	—	115	—	—	140	80	140	—	108 ^b	83	15
20	3/4	150	230	117	152	190	117	95	115	117	64	130	—	120	—	—	152	90	152	25	117 ^b	95	20
25	1	160	230	127	165	216	127	100	115	127	70	140	—	125	120	—	165	100	165	25	216 ^c	108	25
32	1 1/4	180	260	140	178	229	146	105	130	140	76	165	—	130	140	—	178	110	178	33	229 ^d	114	32
40	1 1/2	200	260	165	190	241	159	115	130	165	83	165	106	140	240	33	190	120	190	33	241 ^e	121	40
50	2	230	300	178	216	292	190	125	150	203	102	203	108	150	250	43	216	135	216	43	267	146	50
65	2 1/2	290	340	190	241	330	216	145	170	216	108	222	112	170	270	46	241	165	241	46	292	165	65
80	3	310	380	203	283	356	254	155	190	241	121	241	114	180	280	64	283	185	283	46	318	178	80
100	4	350	430	229	305	432	305	175	215	292	146	305	127	190	300	64	305	229	305	52	356	216	100
125	5	400	500	254	381	508	356	200	250	330 ^g	178	356	140	200	325	70	381	—	381	56	400	254	125
150	6	480	550	267	403	559	406	225	275	356 ^h	203	394	140	210	350	76	403	—	403	56	444	279	150
200	8	600	650	292	419	660	521	275	325	495	248	457	152	230	400	89	502	—	419	60	533 ^f	330	200
250	10	730	775	330	457	787	635	325	—	622	311	533	165	250	450	114	568	—	457	68	622	394	250
300	12	850	900	356	502	838	749	375	—	698	349	610	178	270	500	114	648	—	502	78	711	419	300
350	14	980	1 025	381	762	889	—	425	—	787	394	686	190	290	550	127	762	—	572	78	838	—	350
400	16	1 100	1 150	406	838	991	—	475	575	864 ⁱ	457	762	216	310	600	140	838	—	610	102	864	—	400
450	18	1 200	1 275	432	914	1 092	—	500	—	978	483	864	222	330	650	152	914	—	660	114	978	—	450
500	20	1 250	1 400	457	991	1 194	—	—	700	978	—	914	229	350	700	152	991	—	711	127	1 016	—	500
600	24	1 450	1 650	508	1 143	1 397	—	—	—	1 295	—	1 067	267	390	800	178	1 143	—	787	154	1 346	—	600

NOTE See informative Annex C for the origin of the basic series.

^a CTF dimensions for angle pattern valves.
^b For swing check valve only. For globe valve use 152 for DN15 and 178 for DN20.
^c For swing check valve only. For globe valve use 203.
^d For swing check valve only. For globe valve use 216.
^e For swing check valve only. For globe valve use 229.
^f For swing check valve only. For globe valve use 559.
^g For swing check valve only. For globe valve use 356.
^h For swing check valve only. For globe valve use 406.
ⁱ For swing check valve only. For globe valve use 914.

Table 1 (continued)

Nominal size		Basic series																		DN			
DN	NPS	1	2	3	4	5	7	8 ^a	9 ^a	10	11 ^a	12	13	14	15	16	17	18	19	20	21	24 ^a	
650	26	—	—	559	1 245	1 448	—	—	—	1 295	—	1 143	—	—	—	—	1 245	—	—	—	1 346	—	650
700	28	1 650	—	610	1 346	1 549	—	—	—	1 448	—	—	292	430	900	229	1 346	—	—	165	1 499	—	700
750	30	1 750	—	610	1 397	1 651	—	—	—	1 524	—	1 295	—	—	950	230	1 397	—	—	190	1 594	—	750
800	32	1 850	—	660	1 524	1 778	—	—	—	1 676	—	—	318	470	1 000	241	1 524	—	—	190	1 778	—	800
900	36	2 050	—	711	1 727	2 083	—	—	—	1 956	—	1 600	330	510	1 100	241	1 727	—	—	203	2 083	—	900
1 000	40	2 250	—	813	—	—	—	—	—	—	—	—	410	550	1 200	300	—	—	—	216	—	—	1 000
1 050	42	—	—	—	—	—	—	—	—	—	—	—	—	—	—	—	—	—	—	—	—	—	1 050
1 200	48	—	—	—	—	—	—	—	—	—	—	—	470	630	—	350	—	—	—	254	—	—	1 200
1 400	56	—	—	—	—	—	—	—	—	—	—	—	530	710	—	390	—	—	—	—	—	—	1 400
1 600	64	—	—	—	—	—	—	—	—	—	—	—	600	790	—	440	—	—	—	—	—	—	1 600
1 800	72	—	—	—	—	—	—	—	—	—	—	—	670	870	—	490	—	—	—	—	—	—	1 800
2 000	80	—	—	—	—	—	—	—	—	—	—	—	760	950	—	540	—	—	—	—	—	—	2 000

NOTE See informative Annex C for the origin of the basic series.

^a CTF dimensions for angle pattern valves.

^b For swing check valve only. For globe valve use 152 for DN15 and 178 for DN20.

^c For swing check valve only. For globe valve use 203.

^d For swing check valve only. For globe valve use 216.

^e For swing check valve only. For globe valve use 229.

^f For swing check valve only. For globe valve use 559.

^g For swing check valve only. For globe valve use 356.

^h For swing check valve only. For globe valve use 406.

ⁱ For swing check valve only. For globe valve use 914.

Table 1 — (25-71) (continued)

Nominal size		Basic series																				DN
DN	NPS	25	26	27	28	32 ^a	48	54	55	56	57 ^a	58 ^a	59 ^a	69	70	71	DN					
10	3/8	—	—	115	130	—	—	—	—	—	—	—	—	—	—	—	10					
15	1/2	—	—	115	130	76	—	—	216	264	—	108	132	—	—	—	15					
20	3/4	—	—	120	150	89	—	229	229	273	114	114	137	—	—	—	20					
25	1	—	—	125	160	102	—	254	254	308	127	127	154	140	140	186	25					
32	1 1/4	—	—	130	180	108	—	279	279	349	140	140	175	165	165	232	32					
40	1 1/2	37	240	140	200	114	180	305	305	384	152	152	192	178	178	232	40					
50	2	44	250	150	230	133	200	368	368	451	184	184	226	216	216	279	50					
65	2 1/2	49	290	170	290	146	240	419	419	508	210	210	254	254	254	330	65					
80	3	49	310	180	310	159	260	381	470	578	190	235	289	305	305	368	80					
100	4	56	350	190	350	178	300	457	546	673	229	273	337	356	406	457	100					
125	5	64	400	325	400	200	350	559	673	794	279	337	397	432	483	533	125					
150	6	70	450	350	450	222	400	610	705	914	305	353	457	508	559	610	150					
200	8	71	550	400	550	279	500	737	832	1 022	368	416	511	660	711	762	200					
250	10	76	650	450	650	311	600	838	991	1 270	419	495	635	787	864	914	250					
300	12	83	750	500	750	356	700	965	1 130	1 422	483	565	711	914	991	1 041	300					
350	14	92	850	550	850	—	800	1 029	1 257	—	514	629	—	991	1 067	1 118	350					
400	16	102	950	762	950	—	900	1 130	1 384	—	660	—	—	1 092	1 194	1 245	400					
450	18	114	1 050	—	—	—	1 000	1 219	1 537	—	737	—	—	—	1 346	1 397	450					
500	20	127	1 150	914	1 150	—	1 100	1 321	1 664	—	826	—	1 650	—	1 473	—	500					
600	24	154	1 350	—	—	—	1 300	1 549	1 943	—	991	—	—	—	—	—	600					
650	26	—	—	—	—	—	—	—	—	—	—	—	—	—	—	—	650					
700	28	—	1 550	—	—	—	1 500	—	—	—	—	—	—	—	—	—	700					
750	30	—	—	—	—	—	—	—	—	—	—	—	—	—	—	—	750					
800	32	—	1 750	—	—	—	1 700	—	—	—	—	—	—	—	—	—	800					
900	36	—	1 950	—	—	—	1 900	—	—	—	—	—	—	—	—	—	900					
1 000	40	—	2 150	—	—	—	2 100	—	—	—	—	—	—	—	—	—	1 000					

NOTE See informative Annex C for the origin of the basic series.

^a CTF dimensions for angle pattern valves.

Table 1 (continued)

Nominal size		Basic series															DN
DN	NPS	25	26	27	28	32 ^a	48	54	55	56	57 ^a	58 ^a	59 ^a	69	70	71	DN
1 050	42	—	—	—	—	—	—	—	—	—	—	—	—	—	—	—	1 050
1 200	48	—	—	—	—	—	—	—	—	—	—	—	—	—	—	—	1 200
1 400	56	—	—	—	—	—	—	—	—	—	—	—	—	—	—	—	1 400
1 600	64	—	—	—	—	—	—	—	—	—	—	—	—	—	—	—	1 600
1 800	72	—	—	—	—	—	—	—	—	—	—	—	—	—	—	—	1 800
2 000	80	—	—	—	—	—	—	—	—	—	—	—	—	—	—	—	2 000

NOTE See informative [Annex C](#) for the origin of the basic series.

^a CTF dimensions for angle pattern valves.

Table 1 — (91-132) (continued)

Nominal size		Basic series																	DN
DN	NPS	91	92	93 ^a	98	99	109	110	119	120	121	126	127	128	130	131	132	DN	
10	3/8	—	230	115	65	—	—	—	—	—	—	—	—	—	—	—	—	10	
15	1/2	—	230	115	65	—	—	—	—	—	—	—	—	—	—	—	—	15	
20	3/4	—	260	130	65	—	—	—	—	—	—	—	—	—	—	—	—	20	
25	1	—	260	130	65	—	—	—	—	—	—	—	—	—	—	—	—	25	
32	1 1/4	—	300	150	80	—	—	—	—	—	—	—	—	—	—	—	—	32	
40	1 1/2	310	300	150	85	270	—	—	—	—	—	—	—	—	—	—	—	40	
50	2	350	350	175	100	300	—	—	60	60	70	70	70	70	114	121	165	50	
65	2 1/2	425	400	200	130	360	—	—	67	67	83	83	83	83	—	—	—	65	
80	3	470	450	225	160	390	48	54	73	73	83	83	83	86	121	143	165	80	
100	4	550	520	260	190	450	54	64	73	73	102	102	102	105	121	165	197	100	
125	5	650	600	300	240	525	—	—	—	—	—	—	—	—	—	—	—	125	
150	6	750	700	350	250	600	59	78	98	98	136	159	159	159	130	194	219	150	
200	8	950	800	400	320	750	73	102	127	127	165	206	206	206	152	219	254	200	
250	10	1 150	900	—	—	900	83	117	146	146	213	241	248	254	178	244	267	250	
300	12	1 350	1 050	—	—	1 050	92	140	181	181	229	292	305	305	—	—	—	300	
350	14	1 550	—	—	—	1 200	117	155	184	222	273	356	356	—	—	—	—	350	
400	16	1 750	—	—	—	1 350	133	178	191	232	305	384	384	—	—	—	—	400	
450	18	1 950	—	—	—	1 500	149	200	203	264	362	451	468	—	—	—	—	450	
500	20	2 150	—	—	—	1 650	159	216	219	292	368	451	533	—	—	—	—	500	
600	24	—	—	—	—	—	181	232	222	318	438	495	559	—	—	—	—	600	
650	26	—	—	—	—	—	—	—	222	318	457	533	—	—	—	—	—	650	
700	28	—	—	—	—	—	—	—	305	368	483	572	—	—	—	—	—	700	
750	30	—	—	—	—	—	—	—	305	368	505	635	—	—	—	—	—	750	
800	32	—	—	—	—	—	—	—	356	368	533	660	—	—	—	—	—	800	
900	36	—	—	—	—	—	—	—	368	483	635	718	—	—	—	—	—	900	
1 000	40	—	—	—	—	—	—	—	432	546	660	762	—	—	—	—	—	1 000	

NOTE See informative Annex C for the origin of the basic series.

^a CTF dimensions for angle pattern valves.

Table 1 (continued)

Nominal size		Basic series																	DN
DN	NPS	91	92	93 ^a	98	99	109	110	119	120	121	126	127	128	130	131	132	DN	
1 050	42	—	—	—	—	—	—	—	432	568	701	787	—	—	—	—	—	1 050	
1 200	48	—	—	—	—	—	—	—	524	629	787	—	—	—	—	—	—	1 200	
1 400	56	—	—	—	—	—	—	—	—	—	—	—	—	—	—	—	—	1 400	
1 600	64	—	—	—	—	—	—	—	—	—	—	—	—	—	—	—	—	1 600	
1 800	72	—	—	—	—	—	—	—	—	—	—	—	—	—	—	—	—	1 800	
2 000	80	—	—	—	—	—	—	—	—	—	—	—	—	—	—	—	—	2 000	

NOTE See informative [Annex C](#) for the origin of the basic series.

^a CTF dimensions for angle pattern valves.

Table 2 — Gate valves — PN rating

Dimensions in millimetres

Nominal size		Face-to-face dimensions							
DN	NPS	PN 6 - 10 - 16			PN 25 - 40		PN 63 - 100	PN 160 - 250	PN 250 - 320 - 400
Basic series		3	14	15	15	26	26	99	91
10	3/8	102	115	—	—	—	—	—	—
15	1/2	108	115	—	—	—	—	—	—
20	3/4	117	120	—	—	—	—	—	—
25	1	127	125	120	—	—	—	—	—
32	1 1/4	140	130	140	—	—	—	—	—
40	1 1/2	165	140	240	240	240	240	270	310
50	2	178	150	250	250	250	250	300	350
65	2 1/2	190	170	270	290	290	290	360	425
80	3	203	180	280	310	310	310	390	470
100	4	229	190	300	350	350	350	450	550
125	5	254	200	325	400	400	400	525	650
150	6	267	210	350	450	450	450	600	750
200	8	292	230	400	550	550	550	750	950
250	10	330	250	450	650	650	650	900	1 150
300	12	356	270	500	750	750	750	1 050	1 350
350	14	381	290	550	850	850	850	1 200	1 550
400	16	406	310	600	950	950	950	1 350	1 750
450	18	432	330	650	1 050	1 050	1 050	1 500	1 950
500	20	457	350	700	1 150	1 150	1 150	1 650	2 150
600	24	508	—	800	1 350	1 350	1 350	—	—
650	26	559	—	—	—	—	—	—	—
700	28	610	—	900	1 550	1 550	1 550	—	—
750	30	610	—	950	—	—	—	—	—
800	32	660	—	1 000	1 750	1 750	1 750	—	—
900	36	711	—	1 100	1 950	1 950	1 950	—	—
1 000	40	813	—	1 200	2 150	2 150	2 150	—	—
1 050	42	—	—	—	—	—	—	—	—
1 200	48	—	—	—	—	—	—	—	—

Table 3 — Gate valves — Class rating

Nominal size		Face-to-face dimensions									
DN	NPS	Class 125-150	Class 250	Class 300	Class 600	Class 900		Class 1500		Class 2500	
						Short	Long	Short	Long	Short	Long
Basic series		3	19	4	5	69	54	70	55	71	56
10	3/8	102	—	—	—	—	—	—	—	—	—
15	1/2	108	—	140	165	—	—	—	216	—	264
20	3/4	117	—	152	190	—	229	—	229	—	273
25	1	127	—	165	216	140	254	140	254	186	308
32	1 1/4	140	—	178	229	165	279	165	279	232	349

Table 3 (continued)

Nominal size		Face-to-face dimensions									
DN	NPS	Class 125-150	Class 250	Class 300	Class 600	Class 900		Class 1500		Class 2500	
						Short	Long	Short	Long	Short	Long
Basic series		3	19	4	5	69	54	70	55	71	56
40	1 ½	165	—	190	241	178	305	178	305	232	384
50	2	178	216	216	292	216	368	216	368	279	451
65	2 ½	190	241	241	330	254	419	254	419	330	508
80	3	203	283	283	356	305	381	305	470	368	578
100	4	229	305	305	432	356	457	406	546	457	673
125	5	254	381	381	508	432	551	483	673	533	794
150	6	267	403	403	559	508	610	559	705	610	914
200	8	292	419	419	660	660	737	711	832	762	1 022
250	10	330	457	457	787	787	838	864	991	914	1 270
300	12	356	502	502	838	914	965	991	1 130	1 061	1 422
350	14	381	572	762	889	991	1 029	1 067	1 257	1 118	—
400	16	406	610	838	991	1 092	1 130	1 194	1 384	1 245	—
450	18	432	660	914	1 092	—	1 219	1 346	1 537	1 397	—
500	20	457	711	991	1 194	—	1 321	1 473	1 664	—	—
600	24	508	787	1 143	1 397	—	1 549	—	1 943	—	—
650	26	559	—	1 245	1 448	—	—	—	—	—	—
700	28	610	—	1 346	1 549	—	—	—	—	—	—
750	30	610	—	1 397	1 651	—	—	—	—	—	—
800	32	660	—	1 524	1 778	—	—	—	—	—	—
900	36	711	—	1 727	2 083	—	—	—	—	—	—
1 000	40	813	—	—	—	—	—	—	—	—	—
1 050	42	—	—	—	—	—	—	—	—	—	—
1 200	48	—	—	—	—	—	—	—	—	—	—

Table 4 — Butterfly valves — Flange type — PN rating

Dimensions in millimetres

Nominal size		Face-to-face dimensions		
DN	NPS	PN 2,5 - 6 - 10 - 16 - 25 - 40		PN 63 - 100
		Short series	Long series	
Basic series		13	14	14
25	1	—	—	125
32	1 ¼	—	—	130
40	1 ½	106	140	140
50	2	108	150	150
65	2 ½	112	170	170
80	3	114	180	180
100	4	127	190	190
125	5	140	200	—
150	6	140	210	210
200	8	152	230	230

Table 4 (continued)

Nominal size		Face-to-face dimensions		
DN	NPS	PN 2,5 - 6 - 10 -16 - 25 - 40		PN 63 - 100
		Short series	Long series	
Basic series		13	14	14
250	10	165	250	250
300	12	178	270	270
350	14	190	290	290
400	16	216	310	310
450	18	222	330	330
500	20	229	350	350
600	24	267	390	390
650	26	292	410	—
700	28	292	430	—
750	30	318	450	—
800	32	318	470	—
900	36	330	510	—
1 000	40	410	550	—
1 050	42	410	570	—
1 200	48	470	630	—
1 400	56	530	710	—
1 600	64	600	790	—
1 800	72	670	870	—
2 000	80	760	950	—

Table 5 — Butterfly valves — Flange type — Class rating

Dimensions in millimetres

Nominal size		Face-to-face dimensions			
DN	NPS	Class 125 - 150		Class 250 - 300	Class 600
		Short	Long		
Basic series		13	14	14	14
40	1 ½	106	140	140	140
50	2	108	150	150	150
65	2 ½	112	170	170	170
80	3	114	180	180	180
100	4	127	190	190	190
125	5	140	200	200	200
150	6	140	210	210	210
200	8	152	230	230	230
250	10	165	250	250	250
300	12	178	270	270	270
350	14	190	290	290	290
400	16	216	310	310	310
450	18	222	330	330	330
500	20	229	350	350	350
600	24	267	390	390	390

Table 5 (continued)

Nominal size		Face-to-face dimensions			
DN	NPS	Class 125 - 150		Class 250 - 300	Class 600
		Short	Long		
Basic series		13	14	14	14
650	26	292	410	410	—
700	28	292	430	430	—
750	30	318	450	450	—
800	32	318	470	470	—
900	36	330	510	510	—
1 000	40	410	550	550	—
1 050	42	410	570	570	—
1 200	48	470	630	630	—
1 400	56	530	710	710	—
1 600	64	600	790	790	—
1 800	72	670	870	870	—
2 000	80	760	950	950	—

Table 6 — Butterfly valves — Wafer type — PN rating

Dimensions in millimetres

Nominal size		Face-to-face dimensions			
DN	NPS	PN 2,5 - 6 - 10 -16 - 25 - 40	PN 10 -16- 25 - 40		PN 63 - 100
		Short	Medium	Long	
Basic series		20	25	16	110
25	1	33	—	33	—
32	1 ¼	33	—	33	—
40	1 ½	33	37	33	—
50	2	43	44	43	—
65	2 ½	46	49	46	—
80	3	46	49	64	54
100	4	52	56	64	64
125	5	56	64	70	—
150	6	56	70	76	78
200	8	60	71	89	102
250	10	68	76	114	117
300	12	78	83	114	140
350	14	78	92	127	155
400	16	102	102	140	178
450	18	114	114	152	200
500	20	127	127	152	216
600	24	154	154	178	232
650	26	—	—	—	—
700	28	165	—	229	—
750	30	190	165	230	—
800	32	190	—	241	—

Table 6 (continued)

Nominal size		Face-to-face dimensions			
DN	NPS	PN 2,5 - 6 - 10 -16 - 25 - 40	PN 10 -16- 25 - 40		PN 63 - 100
		Short	Medium	Long	
Basic series		20	25	16	110
900	36	203	200	241	—
1 000	40	216	—	300	—
1 050	42	—	251	—	—
1 200	48	254	276	350	—
1 400	56	—	—	390	—
1 600	64	—	—	440	—
1 800	72	—	—	490	—
2 000	80	—	—	540	—

Table 7 — Butterfly valves — Wafer type — Class rating

Dimensions in millimetres

Nominal size		Face-to-face dimensions						
DN	NPS	Class 125 - 150			Class 250 - 300			Class 600
		Short	Medium	Long	Short	Medium	Long	
Basic series		20	25	16	25	109	16	110
40	1 ½	33	37	33	37	—	33	—
50	2	43	44	43	44	—	43	—
65	2 ½	46	49	46	49	—	46	—
80	3	46	49	64	49	48	64	54
100	4	52	56	64	56	54	64	64
125	5	56	64	70	64	—	70	—
150	6	56	70	76	70	59	76	78
200	8	60	71	89	71	73	89	102
250	10	68	76	114	76	83	114	117
300	12	78	83	114	83	92	114	140
350	14	78	92	127	92	117	127	155
400	16	102	102	140	102	133	140	178
450	18	114	114	152	114	149	152	200
500	20	127	127	152	127	159	152	216
600	24	154	154	178	154	181	178	232
650	26	—	—	—	—	—	—	—
700	28	165	—	229	—	—	229	—
750	30	190	165	230	165	—	230	—
800	32	190	—	241	—	—	241	—
900	36	203	200	241	200	—	241	—
1 000	40	216	—	300	—	—	300	—
1 050	42	—	251	—	251	—	—	—
1 200	48	254	276	350	276	—	350	—
1 400	56	—	—	390	—	—	390	—
1 600	64	—	—	440	—	—	440	—

Table 7 (continued)

Nominal size		Face-to-face dimensions						
DN	NPS	Class 125 - 150			Class 250 - 300			Class 600
		Short	Medium	Long	Short	Medium	Long	
Basic series		20	25	16	25	109	16	110
1 800	72	—	—	490	—	—	490	—
2 000	80	—	—	540	—	—	540	—

Table 8 — Ball valves and plug valves — PN rating

Dimensions in millimetres

Nominal size		Face-to-face dimensions										
DN	NPS	PN 10 - 16				PN 25 - 40					PN 63 - 100	PN 160
		1	12	26	27	1	4	12	26	27		
Basic series		1	12	26	27	1	4	12	26	27	28	98
10	3/8	130	130	—	115	130	—	130	—	115	130	65
15	1/2	130	130	—	115	130	140	130	—	115	130	65
20	3/4	150	130	—	120	150	152	130	—	120	150	65
25	1	160	140	—	125	160	165	140	—	125	160	65
32	1 1/4	180	165	—	130	180	178	165	—	130	180	80
40	1 1/2	200	165	240	140	200	190	165	240	140	200	85
50	2	230	203	250	150	230	216	203	250	150	230	100
65	2 1/2	290	222	290	170	290	241	222	290	170	290	130
80	3	310	241	310	180	310	283	241	310	180	310	160
100	4	350	305	350	190	350	305	305	350	190	350	190
125	5	400	356	400	325	400	381	356	400	325	400	240
150	6	480	394	450	350	480	403	394	450	350	450	250
200	8	600	457	550	400	600	419	457	550	400	550	320
250	10	730	533	650	450	730	457	533	650	450	650	—
300	12	850	610	750	500	850	502	610	750	500	750	—
350	14	980	686	850	550	980	762	686	850	550	850	—
400	16	1 100	762	950	762	1 100	838	762	950	762	950	—
450	18	1 200	864	1 050	—	1 200	914	864	1 050	—	—	—
500	20	1 250	914	1 150	914	1 250	991	914	1 150	914	1 150	—
600	24	1 450	1 067	1 350	—	1 450	1 143	1 067	1 350	—	—	—
650	26	—	—	—	—	—	—	—	—	—	—	—
700	28	1 650	—	1 550	—	1 650	—	—	1 550	—	—	—
750	30	—	—	—	—	—	1 397	—	—	—	—	—
800	32	1 850	—	1 750	—	1 850	—	—	1 750	—	—	—
900	36	2 050	—	1 950	—	2 050	—	—	1 950	—	—	—
1 000	40	2 250	—	2 150	—	2 250	—	—	2 150	—	—	—
1 050	42	—	—	—	—	—	—	—	—	—	—	—
1 200	48	—	—	—	—	—	—	—	—	—	—	—
1 400	56	—	—	—	—	—	—	—	—	—	—	—

Table 9 — Ball valves and plug valves — Class rating

Dimensions in millimetres

Nominal size		Face-to-face dimensions							
DN	NPS	Class 125 - 150		Class 250 - 300		Class 600	Class 900	Class 1 500	Class 2 500
		Medium	Long	Short	Long				
Basic series		12	1	4	1	5	54	55	56
10	3/8	130	130	—	130	—	—	—	—
15	1/2	130	130	140	130	165	—	216	—
20	3/4	130	150	152	150	190	229	229	—
25	1	140	160	165	160	216	254	254	308
32	1 1/4	165	180	178	180	229	279	279	—
40	1 1/2	165	200	190	200	241	305	305	384
50	2	203	230	216	230	292	368	368	451
65	2 1/2	222	290	241	290	330	419	419	508
80	3	241	310	283	310	356	381	470	578
100	4	305	350	305	350	432	457	546	673
125	5	356	400	381	400	508	559	673	—
150	6	394	480	403	480	559	610	705	914
200	8	457	600	419 ^a	600	660	737	832	1 022
250	10	533	730	457 ^b	730	787	838	991	1 270
300	12	610	850	502 ^c	850	838	965	1 130	1 422
350	14	686	980	762	980	889	1 029	1 257	—
400	16	762	1 100	838	1 100	991	1 130	1 384	—
450	18	864	1 200	914	1 200	1 092	1 219	1 537	—
500	20	914	1 250	991	1 250	1 194	1 321	1 664	—
600	24	1 067	1 450	1 143	1 450	1 397	1 549	1 943	—
650	26	1 143	—	1 245	—	1 448	—	—	—
700	28	1 245	1 650	1 346	1 650	1 549	—	—	—
750	30	1 295	1 750	1 397	1 750	1 651	—	—	—
800	32	1 372	1 850	1 524	1 850	1 778	—	—	—
900	36	1 524	2 050	1 727	2 050	2 083	—	—	—
1 000	40	—	2 250	—	2 250	—	—	—	—
1 050	42	—	—	—	—	—	—	—	—
1 200	48	—	—	—	—	—	—	—	—
1 400	56	—	—	—	—	—	—	—	—

^a For full bore ball valves, use 502.

^b For full bore ball valves, use 568.

^c For full bore ball valves, use 648.

Table 10 — Diaphragm valves

Dimensions in millimetres

Nominal size		Face-to-face dimensions	
DN	NPS	PN 10 - 16 - 24 - 40	Class 125 - 150 - 250 - 300
Basic series		1	7
10	3/8	130	108
15	1/2	130	108
20	3/4	150	117
25	1	160	127
32	1 1/4	180	146
40	1 1/2	200	159
50	2	230	190
65	2 1/2	290	216
80	3	310	254
100	4	350	305
125	5	400	356
150	6	480	406
200	8	600	521
250	10	730	635
300	12	850	749 ^a

^a Also used for DN 350, DN 400, DN 450 and DN 500.

Table 11 — Globe valves — Straight and oblique pattern — PN rating

Dimensions in millimetres

Nominal size		Face-to-face dimensions						
DN	NPS	PN 10 - 16			PN 25 - 40		PN 63 -100 - 160	PN 250 - 320 - 400
Basic series		1	14	125	1	125	2	92
10	3/8	130	115	—	130	—	—	230
15	1/2	130	115	—	130	—	210	230
20	3/4	150	120	—	150	—	230	260
25	1	160	125	—	160	—	230	260
32	1 1/4	180	130	—	180	—	260	300
40	1 1/2	200	140	—	200	—	260	300
50	2	230	150	—	230	—	300	350
65	2 1/2	290	170	—	290	—	340	400
80	3	310	180	—	310	—	380	450
100	4	350	190	300	350	300	430	520
125	5	400	200	325	400	325	500	600
150	6	480	210	350	480	350	550	700
200	8	600	230	400	600	400	650	800
250	10	730	250	450	730	450	775	900
300	12	850	270	500	850	500	900	1 050
350	14	980	290	550	980	550	1 025	—
400	16	1 100	310	600	1 100	600	1 150	—

Table 11 (continued)

Nominal size		Face-to-face dimensions						
DN	NPS	PN 10 - 16			PN 25 - 40		PN 63 -100 - 160	PN 250 - 320 - 400
Basic series		1	14	125	1	125	2	92
450	18	1 200	330	650	1 200	650	1 275	—
500	20	1 250	350	700	1 250	700	1 400	—
600	24	1 450	390	—	1 450	—	1 650	—
650	26	—	—	—	—	—	—	—
700	28	1 650	430	1 050	1 650	1 050	—	—
750	30	1 750	—	—	1 750	—	—	—
800	32	1 850	470	1 200	1 850	1 200	—	—
900	36	2 050	510	1 350	2 050	1 350	—	—
1 000	40	2 250	550	1 500	2 250	1 500	—	—

Table 12 — Globe valves — Straight and oblique pattern — Class rating

Dimensions in millimetres

Nominal size		Face-to-face dimensions										
DN	NPS	Class 125 - 150		Class 250 - 300		Class 600	Class 900	Class 900	Class 1 500	Class 1 500	Class 2 500	Class 2 500
		1	10	1	21		Long	Short	Long	Short	Long	Short
Basic series		1	10	1	21	5	69	54	70	55	71	56
10	3/8	—	—	—	—	—	—	—	—	—	—	—
15	1/2	130	108	130	152	165	—	—	—	216	—	264
20	3/4	150	117	150	178	190	—	229	—	229	—	273
25	1	160	127	160	203	216	140	254	140	254	186	308
32	1 1/4	180	140	180	216	229	165	279	165	279	232	349
40	1 1/2	200	165	200	229	241	178	305	178	305	232	384
50	2	230	203	230	267	292	216	368	216	368	279	451
65	2 1/2	290	216	290	292	330	254	419	254	419	330	508
80	3	310	241	310	318	356	305	381	305	470	368	578
100	4	350	292	350	356	432	356	457	406	546	457	673
125	5	400	356	400	400	508	432	551	483	673	533	794
150	6	480	406	480	444	559	508	610	559	705	610	914
200	8	600	495	600	559	660	660	737	711	832	762	1 022
250	10	730	622	730	622	787	787	838	864	991	914	1 270
300	12	850	698	850	711	838	914	965	991	1 130	1 041	1 422
350	14	980	787	980	—	889	991	1 029	1 067	1 257	1 118	—
400	16	1 100	914	1 100	—	991	1 092	1 130	1 194	1 384	1 245	—
450	18	1 200	—	1 200	—	1 092	—	1 219	1 346	1 537	1 397	—
500	20	1 250	—	1 250	—	1 194	—	1 321	1 473	1 664	—	—
600	24	1 450	—	1 450	—	1 397	—	1 549	—	1 943	—	—
650	26	—	—	—	—	—	—	—	—	—	—	—
700	28	1 650	—	1 650	—	1 549	—	—	—	—	—	—
750	30	1 750	—	1 750	—	1 651	—	—	—	—	—	—
800	32	1 850	—	1 850	—	1 651	—	—	—	—	—	—

Table 12 (continued)

Nominal size		Face-to-face dimensions										
DN	NPS	Class 125 - 150		Class 250 - 300		Class 600	Class 900	Class 900	Class 1 500	Class 1 500	Class 2 500	Class 2 500
		1	10	1	21		Long	Short	Long	Short	Long	Short
Basic series		1	10	1	21	5	69	54	70	55	71	56
900	36	2 050	—	2 050	—	2 083	—	—	—	—	—	—
1 000	40	2 250	—	2 250	—	—	—	—	—	—	—	—

Table 13 — Globe valves and lift check valves — Angle pattern — PN rating

Dimensions in millimetres

Nominal size		Centre-to-face dimensions			
DN	NPS	PN 10 - 16 - 25 - 40	PN 63 - 100 - 160		PN 250 - 320 - 400
			Short	Long	
Basic series		8	24	9	93
10	$\frac{3}{8}$	90	—	105	115
15	$\frac{1}{2}$	90	83	105	115
20	$\frac{3}{4}$	95	95	115	130
25	1	100	108	115	130
32	1 $\frac{1}{4}$	105	114	130	150
40	1 $\frac{1}{2}$	115	121	130	150
50	2	125	146	150	175
65	2 $\frac{1}{2}$	145	165	170	200
80	3	155	178	190	225
100	4	175	216	215	260
125	5	200	254	250	300
150	6	225	279	275	350
200	8	275	330	325	400
250	10	325	394	—	—
300	12	375	419	—	—
350	14	425	—	—	—
400	16	475	—	—	—
450	18	500	—	—	—

Table 14 — Globe valves and lift check valves — Angle pattern — Class rating

Dimensions in millimetres

Nominal size		Centre-to-face dimensions					
DN	NPS	Class 125 - 150	Class 250 - 300	Class 600	Class 900	Class 1 500	Class 2 500
		Basic series			11	32	24
10	$\frac{3}{8}$	—	—	—	—	—	—
15	$\frac{1}{2}$	57	76	83	—	108	132
20	$\frac{3}{4}$	64	89	95	114	114	137
25	1	70	102	108	127	127	154
32	1 $\frac{1}{4}$	76	108	114	140	140	175
40	1 $\frac{1}{2}$	83	114	121	152	152	192

Table 14 (continued)

Nominal size		Centre-to-face dimensions					
DN	NPS	Class 125 - 150	Class 250 - 300	Class 600	Class 900	Class 1 500	Class 2 500
Basic series		11	32	24	57	58	59
50	2	102	133	146	184	184	226
65	2 ½	108	146	165	210	210	254
80	3	121	159	178	190	235	289
100	4	146	178	216	229	273	337
125	5	178	200	254	279	337	397
150	6	203	222	279	305	353	457
200	8	248	279	330	368	416	511
250	10	311	311	394	419	495	635
300	12	349	356	419	483	565	711
350	14	394	—	—	514	629	—
400	16	457	—	—	660	—	—
450	18	483	—	—	737	—	—

Table 15 — Flanged check valves ^a — Straight and oblique pattern — PN rating

Dimensions in millimetres

Nominal size		Face-to-face dimensions								
DN	NPS	PN 6 - 10 - 16		PN 6 - 10 - 16 - 25 - 40			PN 63 - 100	PN 63 - 100	PN 160	PN 250 - 320 - 400
Basic series		14	48	1	7 ^b	18 ^b	2	26	99	91
10	¾	115	—	—	108	80	—	—	—	—
15	½	115	—	130	108	80	210	—	—	—
20	¾	120	—	150	117	90	230	—	—	—
25	1	125	—	160	127	100	230	—	—	—
32	1 ¼	130	—	180	146	110	260	—	—	—
40	1 ½	140	180	200	159	120	260	240	270	310
50	2	150	200	230	190	135	300	250	300	350
65	2 ½	170	240	290	216	165	340	290	360	425
80	3	180	260	310	254	185	380	310	390	470
100	4	190	300	350	305	229	430	350	450	550
125	5	200	350	400	—	—	500	400	525	650
150	6	210	400	480	—	—	550	450	600	750
200	8	230	500	600	—	—	650	550	750	950
250	10	250	600	730	—	—	775	650	900	1 150
300	12	270	700	850	—	—	900	750	1 050	1 350
350	14	290	800	980	—	—	1 025	850	1 200	1 550
400	16	310	900	1 100	—	—	1 150	950	1 350	1 750
450	18	330	1 000	1 200	—	—	1 275	1 050	1 500	1 950
500	20	350	1 100	1 250	—	—	1 400	1 150	1 650	2 150
600	24	390	1 300	1 450	—	—	1 650	1 350	—	—
650	26	—	—	—	—	—	—	—	—	—
700	28	430	1 500	1 650	—	—	—	1 550	—	—

Table 15 (continued)

Nominal size		Face-to-face dimensions								
DN	NPS	PN 6 - 10 - 16		PN 6 - 10 - 16 - 25 - 40			PN 63 - 100	PN 63 - 100	PN 160	PN 250 - 320 - 400
Basic series		14	48	1	7 ^b	18 ^b	2	26	99	91
750	30	—	—	1 750	—	—	—	—	—	—
800	32	470	1 700	1 850	—	—	—	1 750	—	—
900	36	510	1 900	2 050	—	—	—	1 950	—	—
1 000	40	550	2 100	2 250	—	—	—	2 150	—	—

^a For lift check valves – angle pattern see [Table 13](#).

^b This series applies to copper alloy check valves only; not to be used for cast iron or steel check valves.

Table 16 — Flanged check valves ^a — Straight and oblique pattern — Class rating

Dimensions in millimetres

Nominal size		Face-to-face dimensions											
DN	NPS	Class 125 - 150 - 250 - 300			Class 150	Class 250 - 300	Class 600	Class 900		Class 1 500		Class 2 500	
		1	7 ^b	18 ^b				10	21	5	Short	Long	Short
10	3/8	—	108	80	—	—	—	—	—	—	—	—	—
15	1/2	130	108	80	108	108	165	—	—	—	216	—	—
20	3/4	150	117	90	117	117	190	—	229	—	229	—	—
25	1	160	127	100	127	216	216	140	254	140	254	186	308
32	1 1/4	180	146	110	140	229	229	165	279	165	279	232	349
40	1 1/2	200	159	120	165	241	241	178	305	178	305	232	384
50	2	230	190	135	203	267	292	216	368	216	368	279	451
65	2 1/2	290	216	165	216	292	330	254	419	254	419	330	508
80	3	310	254	185	241	318	356	305	381	305	470	368	578
100	4	350	305	229	292	356	432	356	457	406	546	457	673
125	5	400	—	—	330	400	508	432	551	483	673	533	794
150	6	480	—	—	356	444	559	508	610	559	705	610	914
200	8	600	—	—	495	533	660	660	737	711	832	762	1 022
250	10	730	—	—	622	622	787	787	838	864	991	914	1 270
300	12	850	—	—	698	711	838	914	965	991	1 130	1 061	1 422
350	14	980	—	—	787	838	889	991	1 029	1 067	1 257	1 118	—
400	16	1 100	—	—	864	864	991	1 092	1 130	1 194	1 384	1 245	—
450	18	1 200	—	—	978	978	1 092	—	1 219	1 346	1 537	1 397	—
500	20	1 250	—	—	978	1 016	1 194	—	1 321	1 473	1 664	—	—
600	24	1 450	—	—	1 295	1 346	1 397	—	1 549	—	1 943	—	—
650	26	—	—	—	1 295	1 346	1 448	—	—	—	—	—	—
700	28	1 650	—	—	1 448	1 499	—	—	—	—	—	—	—
750	30	1 750	—	—	1 524	1 594	1 651	—	—	—	—	—	—
800	32	1 850	—	—	—	1 778	—	—	—	—	—	—	—
900	36	2 050	—	—	1 956	2 083	2 083	—	—	—	—	—	—
1 000	40	2 250	—	—	—	—	—	—	—	—	—	—	—

Table 16 (continued)

Nominal size		Face-to-face dimensions											
DN	NPS	Class 125 - 150 - 250 - 300			Class 150	Class 250 - 300	Class 600	Class 900		Class 1 500		Class 2 500	
		1	7 ^b	18 ^b				10	21	5	Short	Long	Short
Basic series		1	7 ^b	18 ^b	10	21	5	69	54	70	55	71	56

^a For lift check valves – angle pattern see [Table 14](#).

^b This series applies to copper alloy check valves only; not to be used for cast iron or steel check valves.

Table 17 — Check valves — Wafer type, butterfly type — PN rating

Dimensions in millimetres

Nominal size		Face-to-face dimensions										
DN	NPS	PN 6 - 10 - 16						PN 25 - 40				
		16	49	51	95	96	97	16	49	51	96	97
Basic series		16	49	51	95	96	97	16	49	51	96	97
10	3/8	—	—	—	—	—	—	—	—	—	—	—
15	1/2	—	16	—	—	—	—	—	16	—	—	—
20	3/4	—	19	—	—	—	—	—	19	—	—	—
25	1	—	22	—	—	—	—	—	22	—	—	—
32	1 1/4	—	28	—	—	—	14	—	28	—	—	14
40	1 1/2	33	31,5	—	—	—	14	33	31,5	—	—	14
50	2	43	40	54	14	17	14	43	40	54	17	14
65	2 1/2	46	46	60	14	20	14	46	46	60	20	14
80	3	64	50	67	14	24	14	64	50	67	24	14
100	4	64	60	67	14	27	18	64	60	67	27	18
125	5	70	90	83	16	32	18	70	90	83	32	18
150	6	76	106	95	16	32	20	76	106	95	32	20
200	8	89	140	127	18	42	22	89	140	127	42	22
250	10	114	—	140	35	47	26	114	—	140	47	26
300	12	114	—	181	43	52	32	114	—	181	52	32
350	14	127	—	222	—	—	38	127	—	222	—	38
400	16	140	—	232	—	—	44	140	—	232	—	44
450	18	152	—	264	—	—	50	152	—	264	—	50
500	20	152	—	292	—	—	56	152	—	292	—	56
600	24	178	—	318	—	—	62	178	—	318	—	62
650	26	—	—	—	—	—	—	—	—	—	—	—
700	28	229	—	381	—	—	68	229	—	381	—	68
750	30	230	—	—	—	—	—	230	—	—	—	—
800	32	241	—	489	—	—	80	241	—	489	—	80
900	36	241	—	—	—	—	86	241	—	—	—	86
1 000	40	300	—	—	—	—	—	300	—	—	—	—
1 050	42	—	—	—	—	—	—	—	—	—	—	—
1 200	48	350	—	—	—	—	—	350	—	—	—	—
1 400	56	390	—	—	—	—	—	390	—	—	—	—
1 600	64	440	—	—	—	—	—	440	—	—	—	—
1 800	72	490	—	—	—	—	—	490	—	—	—	—

Table 17 (continued)

Nominal size		Face-to-face dimensions										
DN	NPS	PN 6 - 10 - 16					PN 25 - 40					
Basic series		16	49	51	95	96	97	16	49	51	96	97
2 000	80	540	—	—	—	—	—	540	—	—	—	—

NOTE Wafer or butterfly type check valve includes swing check, single and dual plate types. Wafer type check valves of globe-style body type, i.e. nozzle and lift type, dimensions are not included in this document.

Table 18 — Check valves — Wafer type, butterfly type — Class rating

Dimensions in millimetres

Nominal size		Face-to-face dimensions										
DN	NPS	Class 125	Class 150			Class 300			Class 600	Class 900	Class 1 500	Class 2 500
Basic series		51	16	51	119	16	51	120	121	126	127	128
25	1	—	—	—	—	—	—	—	—	—	—	—
32	1 ¼	—	—	—	—	—	—	—	—	—	—	—
40	1 ½	—	33	—	—	33	—	—	—	—	—	—
50	2	54	43	54	60	43	54	60	60	70	70	70
65	2 ½	60	46	60	67	46	60	67	67	83	83	83
80	3	67	64	67	73	64	67	73	73	83	83	86
100	4	67	64	67	73	64	67	73	79	102	102	105
125	5	83	70	83	—	70	83	—	—	—	—	—
150	6	95	76	95	98	76	95	98	136	159	159	159
200	8	127	89	127	127 ^a	89	127	127	165	206	206	206
250	10	140	114	140	146	114	140	146	213 ^c	241	248	254
300	12	181	114	181	181	114	181	181 ^b	229	292	305	305
350	14	222	127	222	184	127	222	222	273	356	356	—
400	16	232	140	232	191	140	232	232	305	384	384	—
450	18	264	152	264	203	152	264	264	362	451	468	—
500	20	292	152	292	219	152	292	292	368	451	533	—
600	24	318	178	318	222	178	318	318	438	495	559	—
650	26	—	—	—	222	—	—	318	457	533	—	—
700	28	381	229	381	305	229	381	368	483	572	—	—
750	30	—	—	—	305	—	—	368	505	635	—	—
800	32	489	241	489	356	241	489	368	533	660	—	—
900	36	—	241	—	368	241	—	483	635	718	—	—
1 000	40	—	300	—	432	300	—	546	660	762	—	—
1 050	42	—	—	—	432	—	—	568	701	787	—	—
1 200	48	—	350	—	524	350	—	629	787	—	—	—
1 400	56	—	390	—	—	390	—	—	—	—	—	—
1 600	64	—	440	—	—	440	—	—	—	—	—	—
1 800	72	—	490	—	—	490	—	—	—	—	—	—
2 000	80	—	540	—	—	540	—	—	—	—	—	—

NOTE Wafer or butterfly type check valve includes swing check, single and dual plate types. Wafer type check valves of globe-style body type, i.e. nozzle and lift type, dimensions are not included in this document.

Table 19 — Check valves — Wafer type, butterfly type, flange type — Class rating

Dimensions in millimetres

Nominal size		Face-to-face dimensions			
DN	NPS	Class 150	Class 300	Class 600	Class 900
Basic series		130	130	131	132
25	1	—	—	—	—
32	1 ¼	—	—	—	—
40	1 ½	—	—	—	—
50	2	114	114	121	165
65	2 ½	—	—	—	—
80	3	121	121	143	165
100	4	121	121	165	197
125	5	—	—	—	—
150	6	130	130	194	219
200	8	—	152	219	254
250	10	—	178	244	267

NOTE This table represents alternate face-to-face dimensions for double flanged valves in sizes and pressure classes which do not have enough distance between backs of flanges to accommodate two sets of standard stud bolts, one set on each end flange, with nuts and nut removal clearances between the valve flanges.

Table 20 — Tolerances of the FTF or CTF dimensions

Dimensions in millimetres

Face-to-face and centre-to-face dimensions of unlined valves				Tolerances
Over (DN)	Up to and including (DN)	Over (NPS)	Up to and including (NPS)	
0	250	0	10	± 2
250	500	10	20	± 3
500	800	20	32	± 4
800	1 000	32	40	± 5
1 000	1 600	40	64	± 6
1 600	2 000	64	80	± 8

Table 21 — Tolerances of parallelism or perpendicularity

Dimensions in millimetres

DN	NPS	c
10 to 25	¾ to 1	0,4
32 to 150	1 ¼ to 6	0,6
200 to 300	8 to 12	0,8
350 to 500	14 to 20	1,0
600 to 800	24 to 32	2,0
900 and higher	36 and higher	3,0

NOTE Refer to [Figure 5](#) for dimension c.

Annex A (normative)

Additional length for valves with ring joint flange

For parallel flanged valves, the values of X given in [Table A.1](#) shall be added to the raised face flanged face-to-face dimensions for flanges suitable for octagonal section or oval ring joints.

For angle pattern valves, one half of the value of X given in [Table A.1](#) shall be added to the dimensions for centre of valve body-to-raised faced dimension.

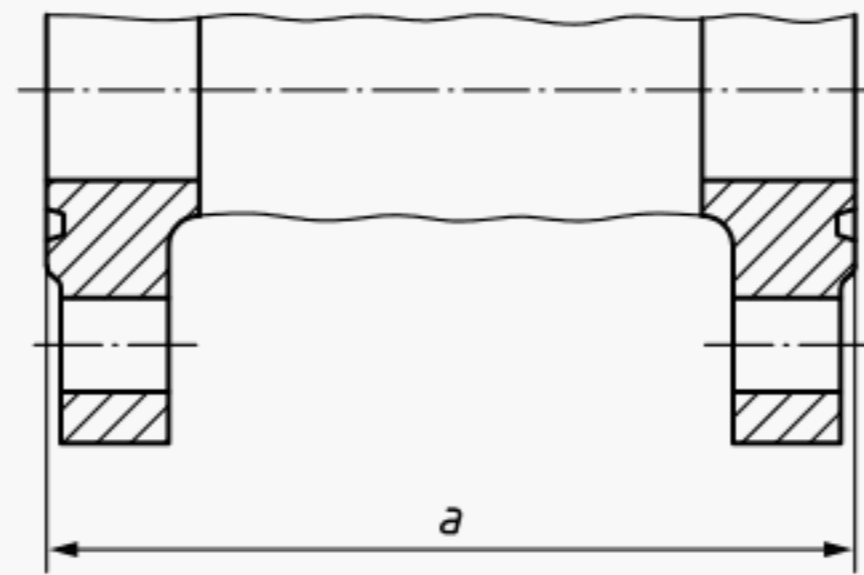

a) FTF for parallel flanged valves with ring joint flanges

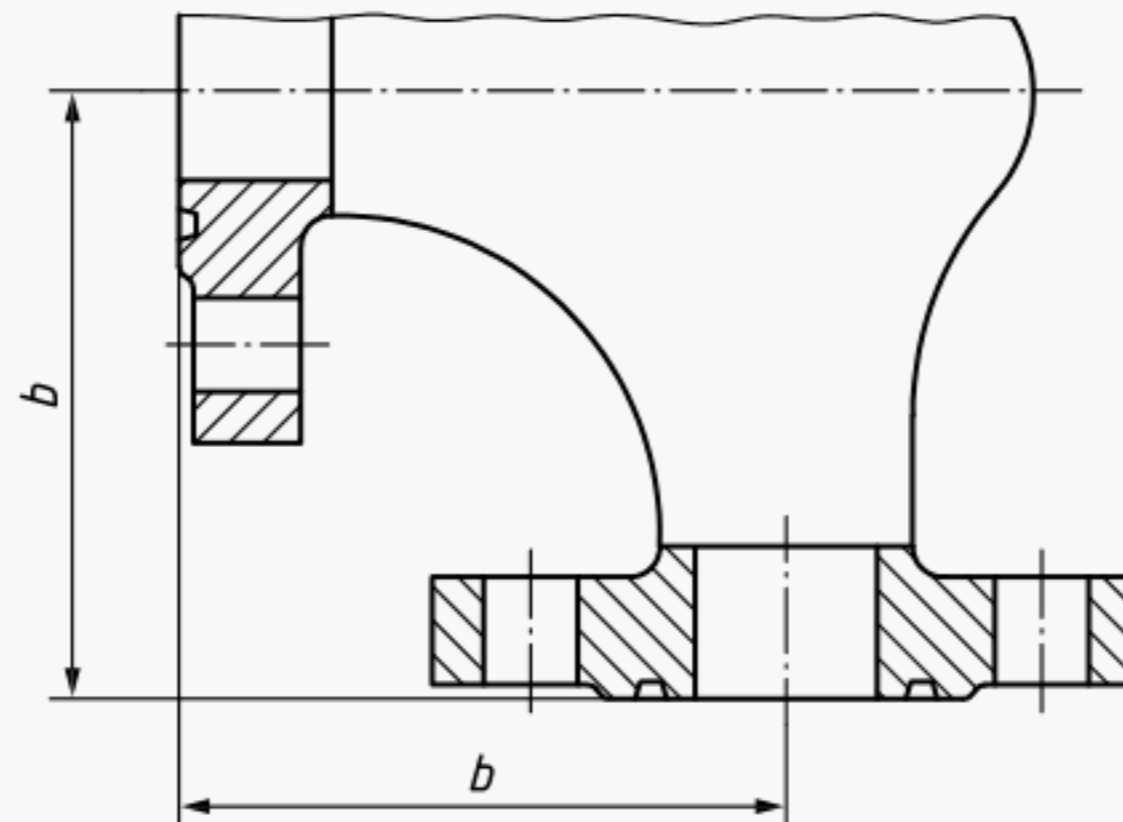

b) CTF for angle pattern valves with ring joint flanges

Key

- a FTF = Dimension of [Table 2](#) + X
- b CTF = Dimension of [Table 2](#) + $0,5 X$

Figure A.1 — Valve with ring joint flange

Table A.1 — Additional length values *X*

Dimensions in millimetres

Nominal size		<i>X</i>					
DN	NPS	Class 150	Class 300	Class 600	Class 900	Class 1 500	Class 2 500
15	½	11,1	11,1	-1,6	0	0	0
20	¾	12,7	12,7	0	0	0	0
25	1	12,7	12,7	0	0	0	0
32	1 ¼	12,7	12,7	0	0	0	3,2
40	1 ½	12,7	15,9	0	0	0	3,2
50	2	12,7	15,9	3,2	3,2	3,2	3,2
65	2 ½	12,7	15,9	3,2	3,2	3,2	6,4
80	3	12,7	15,9	3,2	3,2	3,2	6,4
100	4	12,7	15,9	3,2	3,2	3,2	9,5
125	5	12,7	15,9	3,2	3,2	3,2	12,7
150	6	12,7	15,9	3,2	3,2	6,4	12,7
200	8	12,7	15,9	3,2	3,2	9,5	15,9
250	10	12,7	15,9	3,2	3,2	9,5	22,2
300	12	12,7	15,9	3,2	3,2	15,9	22,2
350	14	12,7	15,9	3,2	9,5	19,1	—
400	16	12,7	15,9	3,2	9,5	22,2	—
450	18	12,7	15,9	3,2	12,7	22,2	—
500	20	12,7	19,1	6,4	12,7	22,2	—
600	24	12,7	22,2	9,5	19,1	28,6	—
650	26	—	25,4	12,7	22,1	—	—
700	28	—	25,4	12,7	22,1	—	—
750	30	—	25,4	12,7	22,1	—	—
800	32	—	28,6	15,9	22,1	—	—
900	36	—	28,6	15,9	28,4	—	—
1 000	40	—	28,6	15,9	—	—	—

Annex B (informative)

Relationship between DN and NPS

Table B.1 — Relationship between DN and NPS

DN	10	15	20	25	32	40	50	65	80	100	125
NPS	$\frac{3}{8}$	$\frac{1}{2}$	$\frac{3}{4}$	1	1 $\frac{1}{4}$	1 $\frac{1}{2}$	2	2 $\frac{1}{2}$	3	4	5
DN	150	200	250	300	350	400	450	500	600	650	700
NPS	6	8	10	12	14	16	18	20	24	26	28
DN	750 ^a	800	900	1 000	1 050 ^a	1 200	1 400	1 500	1 600	1 800	2 000
NPS	30	32	36	40	42	48	56	60	64	72	80
^a This DN is not included in ISO 6708.											

Annex C (informative)

Origin of basic series

When the first edition of ISO 5752 was published in 1979, various series of face-to-face and centre-to-face dimensions were adopted into ISO 5752 from national standards that were current at that time. Each series was given a basic series number and these numbers have been consistently used in subsequent editions of ISO 5752. This policy of allocating basic series numbers to each dimension series was adopted by CEN in EN 558:1995. As additional series have been added to both ISO 5752 and EN 558, these have also been allocated basic series numbers.

In 2000, CEN published EN 12982 which includes dimension series specifically applicable to butt weld ends and each series was allocated a unique basic series number in sequence to the numbers already allocated in ISO 5752 and EN 558.

This annex lists all the basic series numbers whether for flanged valves or for butt weld end valves. It includes series applicable to control valves and to steam traps which are within the scope of the EN standards, but are excluded from this document. This annex is intended to help the reader to understand the origins of the different series and when they were introduced into and deleted from the different versions of the ISO and EN standards. It is also intended to be useful to the committees responsible for the future revisions of applicable standards by providing them with a comprehensive and single source of information regarding the history of development of their standard.

Table C.1 — Origin of basic series

Basic series	Origin	ISO 5752		EN 558	
		Added	Deleted	Added	Deleted
1	DIN 3202-1:1984, Series F 1	1979		1995	
2	DIN 3202-1:1984, Series F 2	1979		1995	
3	ASME B16.10:1973, Table 1, column 9 and 10	1979		1995	
4	ASME B16.10:1973, Table 2, column 10	1979		1995	
5	ASME B16.10:1973, Table 3, column 2 and 7	1982		1995	
6	Never used	N/A		N/A	
7	BS 2080:1989, Table 1, Series 7	1979		1995	
8	DIN 3202-1:1984, Series F 32	1979		1995	
9	DIN 3202-1:1984, Series F 33	1979		1995	
10	ASME B16.10:1973, Table 1, column 17	1979		1995	
11	ASME B16.10:1973, Table 1, column 18	1979		1995	
12	ASME B16.10:1973, Table 1, column 4	1979		1995	
13	BS 2080:1989, Table 1, Series 13 DIN 3202-1:1984, Series F 16	1979		1995	
14	DIN 3202-1:1984, Series F 4	1979		1995	
15	DIN 3202-1:1984, Series F 5	1979		1995	
16	API 609	1979		1995	
17	ASME B16.10:1973, Table 2, column 7	1979		1995	
18	BS 5154	1979		1995	
19	ASME B16.10:1973, Table 2, column 1	1979		1995	

Table C.1 (continued)

Basic series	Origin	ISO 5752		EN 558	
		Added	Deleted	Added	Deleted
20	API 609	1979		1995	
21	ASME B16.10:1973, Table 2, column 15	1979		1995	
22	BS 2080:1989, Table 1, Series 63	N/A		1995	2021
23	BS 2080:1989, Table 1, Series 64	N/A		1995	2021
24	ASME B16.10:1973, Table 3, column 9	1979		1995	
25	ASME B16.10:1973, Table 8, column 4	1979		1995	
26	DIN 3202-1:1984, Series F 7	2021		1995	
27	DIN 3357-2 and following parts	2021		1995	
28	DIN 3357-2 and following parts	2021		1995	
29	NF E 29-377	N/A		1995	
30	NF E 29-377	N/A		1995	
31	Never used	N/A		N/A	
32	ASME B16.10:2017, Table 2, column 16	2021		1995	
33	ASME B16.10:2017, Table 4, column 6	N/A		1995	
34	Never used	N/A		N/A	
35	Never used	N/A		N/A	
36	IEC 60534-3-2:1984, Table 1	N/A		1995	
37	IEC 60534-3-2:1984, Table 1	N/A		1995	
38	IEC 60534-3-2:1984, Table 1	N/A		1995	
39	IEC 60534-3-2:1984, Table 1	N/A		1995	
40	Half the dimensions of series 37	N/A		1995	
41	Half the dimensions of series 38	N/A		1995	
42	Half the dimensions of series 39	N/A		1995	
43	NF E 29-305-2	N/A		1995	
44	NF E 29-305-2	N/A		1995	
45	NF E 29-305-2	N/A		1995	
46	NF E 29-331	N/A		1995	
47	DIN 3202-1:1984, Series F 19	N/A		1995	
48	DIN 3202-1:1984, Series F 6	2021		1995	
49	DIN 3202-3:1979, Series K 4	N/A		1995	
50	NF E 29-377	N/A		1995	
51	NF E 29-377	N/A		1995	
52	DIN 3202-3:1979, Series K 5	N/A		1995	
53	NF E 29-305-2:1988, FR 10	N/A		1995	
54	ASME B16.10:2017, Table 4, column 5	2021		2008	
55	ASME B16.10:2017, Table 5, column 5	2021		2008	
56	ASME B16.10:2017, Table 6, column 1 and 4	2021		2008	
57	ASME B16.10:2017, Table 4, column 7	2021		2008	
58	ASME B16.10:2017, Table 5, column 7	2021		2008	
59	ASME B16.10:2017, Table 6, column 6	2021		2008	
60	ASME B16.10:2017, Table 1, column 9	N/A		N/A	
61	ASME B16.10:2017, Table 1, column 21	N/A		N/A	

Table C.1 (continued)

Basic series	Origin	ISO 5752		EN 558	
		Added	Deleted	Added	Deleted
62	ASME B16.10:2017, Table 1, column 12 and Table 2, column 12	N/A		N/A	
63	ASME B16.10:2017, Table 1, column 20	N/A		N/A	
64	DIN 3202-2:1982, Series S2	N/A		N/A	
65	DIN 3202-2:1982, Series S3	N/A		N/A	
66	DIN 3202-2:1982, Series S5	N/A		N/A	
67	DIN 3202-2:1982, Series S13	N/A		N/A	
68	DIN 3202-2:1982, Series S14	N/A		N/A	
69	ASME B16.10:2017, Table 4, columns 2 and 6	2021		2008	
70	ASME B16.10:2017, Table 5, columns 2 and 6	2021		2008	
71	ASME B16.10:2017, Table 6, columns 2 and 5	2021		2008	
72	ANSI/ISA-75.08.05	N/A		N/A	
73	ANSI/ISA-75.08.05	N/A		N/A	
74	ANSI/ISA-75.08.05	N/A		N/A	
75	ANSI/ISA-75.08.05	N/A		N/A	
76	ANSI/ISA-75.08.05	N/A		N/A	
77	ANSI/ISA-75.16:1994, Table 1	N/A		2008	
78	ASME B16.10:2017, Table 1, column 18	N/A		N/A	
79	Allocated to EN 558	N/A		N/A	
80	Allocated to EN 558	N/A		N/A	
81	NF E 29-470:1983, Table 3	N/A		N/A	
82	ASME B16.10:2017, Table 5, column 8	N/A		2008	
83	DIN 3202-2:1982, Series S31	N/A		N/A	
84	Allocated to EN 558	N/A		N/A	
85	Allocated to EN 558	N/A		N/A	
86	Allocated to EN 558	N/A		N/A	
87	Allocated to EN 558	N/A		N/A	
88	Allocated to EN 558	N/A		N/A	
89	Allocated to EN 558	N/A		N/A	
90	DIN 3202-2:1982, Series S10	N/A		N/A	
91	DIN 3202-1:1984, Series F 9	2021		2008	
92	DIN 3202-1:1984, Series F 3	2021		2008	
93	DIN 3202-1, Series F 34	2021		2008	
94	Allocated to EN 558	N/A		2008	
95	Allocated to EN 558	N/A		2008	
96	Allocated to EN 558	N/A		2008	
97	Allocated to EN 558	N/A		2008	
98	DIN 3202-1	2021		2008	
99	DIN 3202-1:1984, Series F 8	2021		2008	
100	Allocated to EN 558	N/A		2008	
101	Allocated to EN 558	N/A		2008	
102	Allocated to EN 558	N/A		N/A	
103	Allocated to EN 558	N/A		N/A	

Table C.1 (continued)

Basic series	Origin	ISO 5752		EN 558	
		Added	Deleted	Added	Deleted
104	Allocated to EN 558	N/A		N/A	
105	ANSI/ISA-75.08.06:2002, Table 1 (Long)	N/A		2008	
106	ANSI/ISA-75.08.06:2002, Table 1 (Long)	N/A		2008	
107	Allocated to EN 558	N/A		2008	
108	API 609	N/A		2008	
109	API 609	2021		2008	
110	ASME B16.10:2017, Table 8, column 9	2021		2008	
111	ANSI/ISA-75.08.06:2002, Table 1 (Short)	N/A		2017	
112	ANSI/ISA-75.08.06:2002, Table 1 (Short)	N/A		2017	
113	EN 26554:1991, Series 1	N/A		2017	
114	EN 26554:1991, Series 3	N/A		2017	
115	EN 26554:1991, Series 5	N/A		2017	
116	EN 26554:1991, Series 6	N/A		2017	
117	ASME B16.10:2017, Table 7, column 2	N/A		2017	
118	ASME B16.10:2017, Table 7, column 3	N/A		2017	
119	ASME B16.10:2017, Table 7, column 8	2021		2017	
120	ASME B16.10:2017, Table 7, column 9	2021		2017	
121	ASME B16.10:2017, Table 7, column 10	2021		2017	
122	Allocated to EN 558	N/A		2017	
123	Allocated to EN 558	N/A		2017	
124	Allocated to EN 558	N/A		2017	
125	Allocated to EN 558	N/A		2021	
126	ASME B16.10:2017, Table 7, column 11	2021		N/A	
127	ASME B16.10:2017, Table 7, column 12	2021		N/A	
128	ASME B16.10:2017, Table 7, column 13	2021		N/A	
129	Never used	N/A		N/A	
130	API 594:2017, Table 3	2021		N/A	
131	API 594:2017, Table 3	2021		N/A	
132	API 594:2017, Table 3	2021		N/A	

Bibliography

- [1] ISO 6708:1995, *Pipework components — Definition and selection of DN (nominal size)*
- [2] ISO 7268:1983, *Pipe components — Definition of nominal pressure*
- [3] IEC 60534-3-2, *Industrial-process control valves — Part 3: Dimensions — Section two — Face-to-face dimensions for flangeless control valves except wafer butterfly valves*
- [4] API 594:2017, *Check Valves: Flanged, Lug, Wafer, and Butt-Welding*
- [5] API 600, *Steel Gate Valves — Flanged and Butt-Welding Ends, Bolted Bonnets*
- [6] API 609, *Butterfly Valves: Double-flanged, Lug- and Wafer-type*
- [7] API 623, *Steel Globe Valves: Flanged and Butt-welding Ends, Bolted Bonnets*
- [8] ASME B16.5, *Pipe Flanges and Flanged Fittings: NPS 1/2 through NPS 24 Metric/Inch Standard*
- [9] ASME B16.10:1986, *Face to Face and End to End Dimensions of Valves*
- [10] ASME B16.10:2017, *Face-to-Face and End-to-End Dimensions of Valves*
- [11] ASME B16.47, *Large Diameter Steel Flanges: NPS 26 through NPS 60 Metric/Inch Standard*
- [12] ANSI/ISA-75.08.05, *Face-to-Face Dimensions for Buttweld-End Globe-Style Control Valves (Classes 150, 300, 600, 900, 1500, and 2500)*
- [13] ANSI/ISA-75.08.06:2002, *Face-to-Face Dimensions for Flanged Globe-Style Control Valve Bodies (Classes 900, 1500, and 2500)*
- [14] ANSI/ISA-75.16:1994, *Face-to-Face Dimensions for Flanged Globe-Style Control Valve Bodies : ANSI Classes 125, 150, 250, 300 & 60*
- [15] BS 2080:1989, *Specification for face-to-face, centre-to-face, end-to-end and centre-to-end dimensions of valves*
- [16] BS 5353, *Specification for steel plug valves*
- [17] BS 5154, *Specification for copper alloy globe, globe stop and check, check and gate valves*
- [18] DIN 3202-1:1984, *Face-to-face and centre-to-face dimensions; flanged valves*
- [19] DIN 3202-2:1982, *End-to-end and centre-to-end dimensions of valves; Weld-on valves*
- [20] DIN 3202-3:1979, *Face-to-face dimensions of wafer type valves*
- [21] DIN 3357-2, *Full bore steel ball valves*
- [22] DIN 3357-3, *Reduced bore steel ball valves*
- [23] DIN 3357-4, *Full bore nonferrous metal ball valves*
- [24] DIN 3357-5, *Reduced bore nonferrous metal ball valves*
- [25] DIN 3357-6, *Full bore cast iron ball valves*
- [26] DIN 3357-7, *Reduced bore cast iron ball valves*
- [27] EN 558, *Industrial valves — Face-to-face and centre-to-face dimensions of metal valves for use in flanged pipe systems — PN and Class designated valves*

- [28] EN 1092-1, *Flanges and their joints — Circular flanges for pipes, valves, fittings and accessories, PN designated — Part 1: Steel flanges*
- [29] EN 12982, *Industrial valves — End-to-end and centre-to-end dimensions for butt welding end valves*
- [30] EN 26554:1991, *Flanged automatic steam traps — Face-to-face dimensions*
- [31] NF E 29-305-2:1988, *Robinetterie industrielle — Appareils de robinetterie utilisés dans les tuyauteries à brides — Partie 2: Dimensions face à face — Séries FR*
- [32] NF E29-331, *Robinetterie industrielle — Robinets-vannes à brides, en acier — Pression nominale PN 64*
- [33] NF E29-377, *Robinetterie industrielle — Clapets de non-retour métalliques à obturateur à déplacement angulaire à insérer entre brides — Spécifications*
- [34] NF E29-470:1983, *Robinetterie industrielle — Robinets à tournant sphériques en aciers. ISO PN 10. ISO PN 16. ISO PN 20. ISO PN 25. ISO PN 40. ISO PN 50. ISO PN 100*
- [35] NF E29-477, *Robinetterie industrielle — Robinets à tournant, à 3 tubulures d'équerre, en fonte, à brides — Pression nominale PN 10*

British Standards Institution (BSI)

BSI is the national body responsible for preparing British Standards and other standards-related publications, information and services.

BSI is incorporated by Royal Charter. British Standards and other standardization products are published by BSI Standards Limited.

About us

We bring together business, industry, government, consumers, innovators and others to shape their combined experience and expertise into standards-based solutions.

The knowledge embodied in our standards has been carefully assembled in a dependable format and refined through our open consultation process. Organizations of all sizes and across all sectors choose standards to help them achieve their goals.

Information on standards

We can provide you with the knowledge that your organization needs to succeed. Find out more about British Standards by visiting our website at bsigroup.com/standards or contacting our Customer Services team or Knowledge Centre.

Buying standards

You can buy and download PDF versions of BSI publications, including British and adopted European and international standards, through our website at bsigroup.com/shop, where hard copies can also be purchased.

If you need international and foreign standards from other Standards Development Organizations, hard copies can be ordered from our Customer Services team.

Copyright in BSI publications

All the content in BSI publications, including British Standards, is the property of and copyrighted by BSI or some person or entity that owns copyright in the information used (such as the international standardization bodies) and has formally licensed such information to BSI for commercial publication and use.

Save for the provisions below, you may not transfer, share or disseminate any portion of the standard to any other person. You may not adapt, distribute, commercially exploit or publicly display the standard or any portion thereof in any manner whatsoever without BSI's prior written consent.

Storing and using standards

Standards purchased in soft copy format:

- A British Standard purchased in soft copy format is licensed to a sole named user for personal or internal company use only.
- The standard may be stored on more than one device provided that it is accessible by the sole named user only and that only one copy is accessed at any one time.
- A single paper copy may be printed for personal or internal company use only.

Standards purchased in hard copy format:

- A British Standard purchased in hard copy format is for personal or internal company use only.
- It may not be further reproduced – in any format – to create an additional copy. This includes scanning of the document.

If you need more than one copy of the document, or if you wish to share the document on an internal network, you can save money by choosing a subscription product (see 'Subscriptions').

Reproducing extracts

For permission to reproduce content from BSI publications contact the BSI Copyright and Licensing team.

Subscriptions

Our range of subscription services are designed to make using standards easier for you. For further information on our subscription products go to bsigroup.com/subscriptions.

With **British Standards Online (BSOL)** you'll have instant access to over 55,000 British and adopted European and international standards from your desktop. It's available 24/7 and is refreshed daily so you'll always be up to date.

You can keep in touch with standards developments and receive substantial discounts on the purchase price of standards, both in single copy and subscription format, by becoming a **BSI Subscribing Member**.

PLUS is an updating service exclusive to BSI Subscribing Members. You will automatically receive the latest hard copy of your standards when they're revised or replaced.

To find out more about becoming a BSI Subscribing Member and the benefits of membership, please visit bsigroup.com/shop.

With a **Multi-User Network Licence (MUNL)** you are able to host standards publications on your intranet. Licences can cover as few or as many users as you wish. With updates supplied as soon as they're available, you can be sure your documentation is current. For further information, email cservices@bsigroup.com.

Revisions

Our British Standards and other publications are updated by amendment or revision.

We continually improve the quality of our products and services to benefit your business. If you find an inaccuracy or ambiguity within a British Standard or other BSI publication please inform the Knowledge Centre.

Useful Contacts

Customer Services

Tel: +44 345 086 9001

Email: cservices@bsigroup.com

Subscriptions

Tel: +44 345 086 9001

Email: subscriptions@bsigroup.com

Knowledge Centre

Tel: +44 20 8996 7004

Email: knowledgecentre@bsigroup.com

Copyright & Licensing

Tel: +44 20 8996 7070

Email: copyright@bsigroup.com

BSI Group Headquarters

389 Chiswick High Road London W4 4AL UK