

ASME B16.25-2017
(Revision of ASME B16.25-2012)

Buttwelding Ends

AN AMERICAN NATIONAL STANDARD



The American Society of
Mechanical Engineers

ASME B16.25-2017
(Revision of ASME B16.25-2012)

Buttwelding Ends

Get more FREE standards from Standard Sharing Group and our chats

AN AMERICAN NATIONAL STANDARD



**The American Society of
Mechanical Engineers**

Two Park Avenue • New York, NY • 10016 USA

Date of Issuance: December 29, 2017

The next edition of this Standard is scheduled for publication in 2022.

ASME issues written replies to inquiries concerning interpretations of technical aspects of this Standard. Periodically certain actions of the ASME B16 Committee may be published as Cases. Cases and interpretations are published on the ASME Web site under the Committee Pages at <http://cstools.asme.org/> as they are issued.

Errata to codes and standards may be posted on the ASME Web site under the Committee Pages to provide corrections to incorrectly published items, or to correct typographical or grammatical errors in codes and standards. Such errata shall be used on the date posted.

The Committee Pages can be found at <http://cstools.asme.org/>. There is an option available to automatically receive an e-mail notification when errata are posted to a particular code or standard. This option can be found on the appropriate Committee Page after selecting “Errata” in the “Publication Information” section.

ASME is the registered trademark of The American Society of Mechanical Engineers.

This code or standard was developed under procedures accredited as meeting the criteria for American National Standards. The Standards Committee that approved the code or standard was balanced to assure that individuals from competent and concerned interests have had an opportunity to participate. The proposed code or standard was made available for public review and comment that provides an opportunity for additional public input from industry, academia, regulatory agencies, and the public-at-large.

ASME does not “approve,” “rate,” or “endorse” any item, construction, proprietary device, or activity.

ASME does not take any position with respect to the validity of any patent rights asserted in connection with any items mentioned in this document, and does not undertake to insure anyone utilizing a standard against liability for infringement of any applicable letters patent, nor assume any such liability. Users of a code or standard are expressly advised that determination of the validity of any such patent rights, and the risk of infringement of such rights, is entirely their own responsibility.

Participation by federal agency representative(s) or person(s) affiliated with industry is not to be interpreted as government or industry endorsement of this code or standard.

ASME accepts responsibility for only those interpretations of this document issued in accordance with the established ASME procedures and policies, which precludes the issuance of interpretations by individuals.

No part of this document may be reproduced in any form,
in an electronic retrieval system or otherwise,
without the prior written permission of the publisher.

The American Society of Mechanical Engineers
Two Park Avenue, New York, NY 10016-5990

Copyright © 2017 by
THE AMERICAN SOCIETY OF MECHANICAL ENGINEERS
All rights reserved
Printed in U.S.A.

CONTENTS

Foreword		iv
Committee Roster		v
Correspondence With the B16 Committee		vi
Summary of Changes		viii
List of Changes in Record Number Order		ix
1	Scope	1
2	Transition Contours	1
3	Welding Bevel Design	2
4	Preparation of Inside Diameter of Welding End	2
5	Tolerances	3
 Mandatory Appendices		
I	Inch Table	15
II	References	22
 Nonmandatory Appendix		
A	Quality System Program	23
 Figures		
1	Maximum Envelope for Welding End Transitions	4
2	Bevels for Wall Thickness Over 3 mm (0.12 in.) to 22 mm (0.88 in.), Inclusive	5
3	Weld Bevel Details for Wall Thickness Over 22 mm (0.88 in.)	6
4	Weld Bevel Details for GTAW Root Pass [Wall Thickness Over 3 mm (0.12 in.) to 10 mm (0.38 in.), Inclusive]	7
5	Weld Bevel Details for GTAW Root Pass [Wall Thickness Over 10 mm (0.38 in.) to 25 mm (1.0 in.), Inclusive]	7
6	Weld Bevel Details for GTAW Root Pass [Wall Thickness Over 25 mm (1.0 in.)]	8
 Tables		
1	Dimensions of Welding Ends, Metric	9
I-1	Dimensions of Welding Ends, U.S. Customary	16

Get more FREE standards from Standard Sharing Group and our chats

FOREWORD

In July 1953, the American Welding Society presented a proposal on Welding End Preparation to Sectional Committee B16 of the American Standards Association (ASA), with the recommendation that it be considered as a candidate for an American Standard. The proposal was expanded to include welding preparation for flanges and valves covered by ASA B16.5, Steel Pipe Flanges and Flanged Fittings, and for fittings covered by ASA B16.9, Buttwelding Fittings. Consideration was also given to Pipe Fabrication Institute Standard ES-1.

The third draft reviewed by Subcommittee 3, Subgroup 6 (now Subcommittee F), of the B16 Sectional Committee was forwarded to the Committee, cosponsor organizations, and then ASA for approval. Final approval was given on September 14, 1955, with the designation ASA B16.25-1955.

Revisions were developed as a need for clarification and improvements became known and were approved as ASA B16.25-1958 and ASA B16.25-1964. After ASA reorganized as the American National Standards Institute (ANSI) and the Sectional Committee became American National Standards Committee B16, a further revision was approved as ANSI B16.25-1972.

Subcommittee F immediately began work on a major expansion and updating of the Standard, adding illustrations and requirements for welding end configurations applicable to a number of specific circumstances, including cast steel and alloy valves. When a draft had been developed that overcame the many problems and conflicting demands, the Standards Committee, cosecretariat organizations, and ANSI concurred in approval of ANSI B16.25-1979 on July 18, 1979.

In 1982, American National Standards Committee B16 was reorganized as an ASME committee operating under procedures accredited by ANSI. In the 1986 edition, inch dimensions were established as the standard, and numerous changes in text and format were made. Notes for illustrations were also clarified. Following approval by the Standards Committee and ASME, approval as an American National Standard was given by ANSI on October 8, 1986, with the new designation ASME/ANSI B16.25-1986.

In 1992, the subcommittee revised the requirements for the preparation of the inside diameter of welding end. The references in Annex B were also updated. After public review and approval by ASME, this edition was approved by ANSI on October 26, 1992, with the new designation ASME B16.25-1992.

In the 1997 edition, metric dimensions were added as an independent but equal standard to the inch units. An Annex was also added to reference quality system requirements. Following approval by the Standards Committee and ASME, this revision to the 1992 edition of B16.25 was approved as an American National Standard by ANSI on April 17, 1997, with the new designation ASME B16.25-1997.

In the 2003 edition, the reference standard dates were updated. There were clarifications to text made to address inquiries. Tolerances on bevel angles were modified slightly. Following approval by the Standards Committee and ASME, this revision to the 1997 edition of B16.25 was approved as an American National Standard by ANSI on December 17, 2003, with the new designation ASME B16.25-2003.

In the 2007 edition, buttwelding end data were extended to cover requirements for sizes up to NPS 48 (DN 1200). The reference data were updated, and the interpretation section was removed from the Standard.

In the 2012 edition, the references in [Mandatory Appendix II](#) were updated, and notes were updated in the included tables.

In this 2017 edition, provisions have been made to update verbiage and readings. Following the approval by the ASME B16 Standards Committee, approval as an American National Standard was given by ANSI on September 7, 2017.

ASME B16 COMMITTEE

Standardization of Valves, Flanges, Fittings, and Gaskets

(The following is the roster of the Committee at the time of approval of this Standard.)

STANDARDS COMMITTEE OFFICERS

R. M. Bojarczuk, *Chair*
C. E. Davila, *Vice Chair*
C. R. Ramcharran, *Secretary*

STANDARDS COMMITTEE PERSONNEL

A. Appleton , Alloy Stainless Products Co., Inc.	R. C. Merrick , Fluor Enterprises
J. E. Barker , Dezurik Water Controls	M. L. Nayyar , NICE
K. Barron , Ward Manufacturing	W. H. Patrick , Dow Chemical Co.
D. C. Bayreuther , Metso Automation	D. Raho , CCM 2000
W. B. Bedesem , Consultant	C. R. Ramcharran , The American Society of Mechanical Engineers
R. M. Bojarczuk , ExxonMobil Research & Engineering Co.	D. F. Reid , VSP Technologies
A. M. Cheta , Qatar Shell GTL	R. A. Schmidt , Canadoil
M. A. Clark , NIBCO, Inc.	J. P. Tucker , Flowserve Corp.
G. A. Cuccio , Capitol Manufacturing Co.	F. R. Volstadt , Volstadt & Associates, Inc.
J. D'Avanzo , Fluoroseal Valves	F. Feng , <i>Delegate</i> , China Productivity Center For Machinery
C. E. Davila , Crane Energy	R. W. Barnes , <i>Contributing Member</i> , Anric Enterprises, Inc.
K. S. Felder , Valero Energy	P. V. Craig , <i>Contributing Member</i> , Jomar Group
D. R. Frikken , Becht Engineering Co., Inc.	B. G. Fabian , <i>Contributing Member</i> , Pennsylvania Machine Works
D. Hunt, Jr. , Fastenal	M. Katcher , <i>Contributing Member</i> , Haynes International
G. A. Jolly , Samshin Ltd.	A. G. Kireta, Jr. , <i>Contributing Member</i> , Copper Development Association, Inc.
E. J. Lain , Exelon Nuclear	
T. A. McMahon , Emerson Process Management	

SUBCOMMITTEE F — STEEL-THREADED AND WELDING FITTINGS

B. G. Fabian , <i>Chair</i> , Pennsylvania Machine Works	P. W. Heald , Bonney Forge
R. A. Schmidt , <i>Vice Chair</i> , Canadoil	D. Hunt, Jr. , Fastenal
E. Lawson , <i>Secretary</i> , The American Society of Mechanical Engineers	G. A. Jolly , Samshin Ltd.
J. Oh , <i>Secretary</i> , The American Society of Mechanical Engineers	F. Kavarana , CBI, Inc.
A. Appleton , Alloy Stainless Products Co., Inc.	W. Pritzl , Erne Fittings GmbH
G. A. Cuccio , Capitol Manufacturing Co.	J. P. Tucker , Flowserve Corp.
J. G. Dominguez , Welding Outlets, Inc.	G. T. Walden , Wolseley
K. W. Doughty , CB&I Alloy Piping Products	M. M. Zaidi , Jacobs Engineering Group, Inc.
J. P. Ellenberger	C. J. Lafferty , <i>Alternate</i> , U.S. Drop Forge Co.
D. R. Frikken , Becht Engineering Co., Inc.	

CORRESPONDENCE WITH THE B16 COMMITTEE

General. ASME Standards are developed and maintained with the intent to represent the consensus of concerned interests. As such, users of this Standard may interact with the Committee by requesting interpretations, proposing revisions or a case, and attending Committee meetings. Correspondence should be addressed to:

Secretary, B16 Standards Committee
The American Society of Mechanical Engineers
Two Park Avenue
New York, NY 10016-5990
<http://go.asme.org/Inquiry>

Proposing Revisions. Revisions are made periodically to the Standard to incorporate changes that appear necessary or desirable, as demonstrated by the experience gained from the application of the Standard. Approved revisions will be published periodically.

The Committee welcomes proposals for revisions to this Standard. Such proposals should be as specific as possible, citing the paragraph number(s), the proposed wording, and a detailed description of the reasons for the proposal, including any pertinent documentation.

Proposing a Case. Cases may be issued to provide alternative rules when justified, to permit early implementation of an approved revision when the need is urgent, or to provide rules not covered by existing provisions. Cases are effective immediately upon ASME approval and shall be posted on the ASME Committee Web page.

Requests for Cases shall provide a Statement of Need and Background Information. The request should identify the Standard and the paragraph, figure, or table number(s), and be written as a Question and Reply in the same format as existing Cases. Requests for Cases should also indicate the applicable edition(s) of the Standard to which the proposed Case applies.

Interpretations. Upon request, the B16 Standards Committee will render an interpretation of any requirement of the Standard. Interpretations can only be rendered in response to a written request sent to the Secretary of the B16 Standards Committee.

Requests for interpretation should preferably be submitted through the online Interpretation Submittal Form. The form is accessible at <http://go.asme.org/InterpretationRequest>. Upon submittal of the form, the Inquirer will receive an automatic e-mail confirming receipt.

If the Inquirer is unable to use the online form, he/she may e-mail the request to the Secretary of the B16 Standards Committee at SecretaryB16@asme.org, or mail it to the above address. The request for an interpretation should be clear and unambiguous. It is further recommended that the Inquirer submit his/her request in the following format:

- Subject: Cite the applicable paragraph number(s) and the topic of the inquiry in one or two words.
- Edition: Cite the applicable edition of the Standard for which the interpretation is being requested.
- Question: Phrase the question as a request for an interpretation of a specific requirement suitable for general understanding and use, not as a request for an approval of a proprietary design or situation. Please provide a condensed and precise question, composed in such a way that a “yes” or “no” reply is acceptable.
- Proposed Reply (Replies): Provide a proposed reply(ies) in the form of “Yes” or “No,” with explanation as needed. If entering replies to more than one question, please number the questions and replies.
- Background Information: Provide the Committee with any background information that will assist the Committee in understanding the inquiry. The Inquirer may also include any plans or drawings that are necessary to explain the question; however, they should not contain proprietary names or information.

Requests that are not in the format described above may be rewritten in the appropriate format by the Committee prior to being answered, which may inadvertently change the intent of the original request.

Moreover, ASME does not act as a consultant for specific engineering problems or for the general application or understanding of the Standard requirements. If, based on the inquiry information submitted, it is the opinion of the Committee that the inquirer should seek assistance, the inquiry will be returned with the recommendation that such assistance be obtained.

ASME procedures provide for reconsideration of any interpretation when or if additional information that might affect an interpretation is available. Further, persons aggrieved by an interpretation may appeal to the cognizant ASME Committee or Subcommittee. ASME does not “approve,” “certify,” “rate,” or “endorse” any item, construction, proprietary device, or activity.

Attending Committee Meetings. The B16 Standards Committee regularly holds meetings and/or telephone conferences that are open to the public. Persons wishing to attend any meeting and/or telephone conference should contact the Secretary of the B16 Standards Committee.

Get more FREE standards from Standard Sharing Group and our chats

ASME B16.25-2017

SUMMARY OF CHANGES

Following approval by the ASME B16 Committee and ASME, and after public review, ASME B16.25-2017 was approved by the American National Standards Institute on September 7, 2017.

ASME B16.25-2017 includes the following changes identified by a margin note, **(17)**. The Record Numbers listed below are explained in more detail in the "List of Changes in Record Number Order" following this Summary of Changes.

<i>Page</i>	<i>Location</i>	<i>Change (Record Number)</i>
2	4.2	Revised (14-1123)
3	5.3	In-text table revised (14-1123)
3	5.4	Revised in its entirety (15-862)
4	Figure 1	(1) t_{nom} and associated arrows deleted (15-862) (2) Note (4) moved to underneath t_{min} (15-862) (3) Note (5)(b) revised (15-862)
9	Table 1	Revised in its entirety (14-1123)
16	Table I-1	Revised in its entirety (14-1123)
22	Mandatory Appendix II	Updated (16-802)

LIST OF CHANGES IN RECORD NUMBER ORDER

<u>Record Number</u>	<u>Change</u>
14-1123	Revised to incorporate the values currently found in ASME B36.19M per para. 5.4, Tables I and I-1, and Appendix II.
15-862	Revised to incorporate the values currently found in ASME B36.19M per para. 5.4, Tables I and I-1, and Appendix II.
16-802	Updated to reflect the latest references.

Get more FREE standards from Standard Sharing Group and our chats

INTENTIONALLY LEFT BLANK

BUTTWELDING ENDS

1 SCOPE

1.1 General

This Standard covers the preparation of butt welding ends of piping components to be joined into a piping system by welding. It includes requirements for welding bevels, for external and internal shaping of heavy-wall components, and for preparation of internal ends (including dimensions and tolerances). Coverage includes preparation for joints with the following:

- (a) no backing rings
- (b) split or noncontinuous backing rings
- (c) solid or continuous backing rings
- (d) consumable insert rings
- (e) gas tungsten arc welding (GTAW) of the root pass

Details of preparation for any backing ring must be specified when ordering the component.

1.2 Application

This Standard applies to any metallic materials for which a welding procedure can be satisfactorily qualified but does not prescribe specific welding processes or procedures. Unless otherwise specified by the purchaser, it does not apply to welding ends conforming to ASME B16.5, B16.9, or B16.47.

1.3 Relevant Units

This Standard states values in both SI (Metric) and U.S. Customary units. These systems of units are to be regarded separately as standard. Within the text, the U.S. Customary units are shown in parentheses or in a separate table that appears in [Mandatory Appendix I](#). The values stated in each system are not exact equivalents; therefore, it is required that each system of units be used independently of the other. Combining values from the two systems constitutes nonconformance with the Standard.

1.4 Size

Nominal pipe size (NPS), followed by a dimensionless number, is the designation for nominal fitting size. NPS is related to the reference nominal diameter (DN) used in international standards. The relationship is typically as follows:

NPS	DN
$\frac{1}{2}$	15
$\frac{3}{4}$	20
1	25
$1\frac{1}{4}$	32
$1\frac{1}{2}$	40
2	50
$2\frac{1}{2}$	65
3	80
4	100

For $NPS \geq 4$, the related $DN = 25 \times NPS$.

1.5 Referenced Standards

Standards and specifications adopted by reference in this Standard are shown in [Mandatory Appendix II](#). It is not considered practical to identify the specific edition of each standard and specification in the individual references. Instead, the specific edition reference is identified in [Mandatory Appendix II](#). A product made in conformance with a prior edition of referenced standards will be considered to be in conformance, even though the edition reference may be changed in a subsequent revision of the standard.

1.6 Quality Systems

Nonmandatory requirements relating to the manufacturer's quality system program are described in [Nonmandatory Appendix A](#).

1.7 Convention

For determining conformance with this Standard, the convention for fixing significant digits where limits (maximum and minimum values) are specified shall be as defined in ASTM E29. This requires that an observed or calculated value be rounded off to the nearest unit in the last right-hand digit used for expressing the limit. Decimal values and tolerances do not imply a particular method of measurement.

2 TRANSITION CONTOURS

[Figure 1](#) delineates the maximum envelope in which transitions from welding bevel to the outer surface of the component and from the root face to the inner surface of the component must lie. Except as specified in Note (5) to [Figure 1](#), and as otherwise specified by the purchaser, the exact contour within this envelope is the manufacturer's option, provided it maintains the specified minimum wall thickness, has no slopes

steeper than those indicated for the respective regions, and includes the proper surface for backing rings if specified.

3 WELDING BEVEL DESIGN

3.1 Bevels for Other Than GTAW Root Pass

(a) Components having nominal wall thicknesses of 3 mm (0.12 in.) and less shall have ends cut square or slightly chamfered.

(b) Components having nominal wall thicknesses over 3 mm (0.12 in.) to 22 mm (0.88 in.) inclusive shall have single angle bevels as illustrated in Figure 2.

(c) Components having nominal wall thicknesses greater than 22 mm (0.88 in.) shall have compound angle bevels as illustrated in Figure 3.

3.2 Bevels for GTAW Root Pass

(a) Components having nominal wall thicknesses of 3 mm (0.12 in.) and less shall have ends cut square or slightly chamfered.

(b) Components having nominal wall thicknesses over 3 mm (0.12 in.) to 10 mm (0.38 in.) inclusive shall have $37\frac{1}{2}$ -deg \pm $2\frac{1}{2}$ -deg bevels or slightly concave bevels (see Figure 4).

(c) Components having nominal wall thicknesses over 10 mm (0.38 in.) to 25 mm (1.0 in.) inclusive shall have bevels as shown in Figure 5.

(d) Components having nominal wall thicknesses greater than 25 mm (1.0 in.) shall have bevels as shown in Figure 6.

3.3 Outside Diameter at Welding Ends

Dimension *A* shall be either that specified in the applicable component standard or that specified in the purchaser's component specification. In the absence of a requirement for dimension *A* in a component standard or a purchaser's specification, the values for dimension *A* in Table 1 or Table I-1 may be used.

4 PREPARATION OF INSIDE DIAMETER OF WELDING END

4.1 General

Preparation of the inside diameter at the end of a component shall be in accordance with one of the following, as specified by the purchaser:

(a) Components to be welded without backing rings shall meet the requirements of the standard or specification for the component.

(b) Components to be welded using split or noncontinuous backing rings shall be contoured with a cylindrical surface at the end as shown in Figure 2, illustration (b) and Figure 3, illustration (b). If the backing ring contour is

other than rectangular, details must be furnished by the purchaser.

(c) Components to be welded using solid or continuous backing rings shall be contoured with a cylindrical or tapered surface at the end as specified by the purchaser. End preparation is illustrated in Figure 2, illustration (c) and Figure 3, illustration (c) for rectangular ends and in Figure 2, illustration (d) and Figure 3, illustration (d) for tapered ends.

(d) Components to be welded using consumable insert rings or GTAW root pass shall be contoured with a cylindrical surface at the end as shown in Figures 4 through 6.

4.2 Dimension C

(17)

Values for dimension *C* shown in Figure 2, illustrations (c) and (d); Figure 3, illustrations (c) and (d); and Figures 5 and 6 can be determined by the following equations:

(SI Units)

$$C = A - \text{O.D. tolerance} - 2 \times t_{\min} - 0.25 \quad (1)$$

(U.S. Customary Units)

$$C = A - \text{O.D. tolerance} - 2 \times t_{\min} - 0.010 \quad (2)$$

where

A = specified outside pipe diameter at welding end (see para. 3.3)

O.D. tolerance = undertolerance on the pipe O.D. from the applicable piping specification

t_{\min} = *t* - manufacturing tolerance for pipe wall thickness per applicable pipe specification, mm (in.)

t = nominal wall thickness of pipe, mm (in.)

0.25 (0.010) = plus machining tolerance on bore *C*, mm (in.)

Based on tolerances specific to ASTM A106 [50 ≤ DN ≤ 1 200 (2 ≤ NPS ≤ 48)] and A335 [50 ≤ DN ≤ 300 (2 ≤ NPS ≤ 12)] pipe, including an undertolerance on wall thickness of 12.5%, eqs. (1) and (2) can be defined as follows:

(SI Units)

$$C = A - 0.79 - 2 \times 0.875t - 0.25$$

(U.S. Customary Units)

$$C = A - 0.031 - 2 \times 0.875t - 0.010$$

Tables 1 and I-1 list the *C* values for pipe with an undertolerance on *A* of 0.79 mm (0.031 in.) and 12.5% on wall thickness for DN 50 to DN 1500 (NPS 2 to NPS 60) pipe. An undertolerance on *A* of 0.4 mm (0.015 in.) and wall thickness of 12.5% was used for DN 40 (NPS 1½) and smaller pipe. For pipe with an *A* or pipe wall thickness undertolerance other than the above, do not use the *C* data from Tables 1 and I-1 [see para. 4.3(a)].

4.3 Exceptions

(a) For pipe or tubing varying from the ASTM A106 and A335 types, having different wall thickness and/or outside diameter tolerances (such as forged and bored pipe), the foregoing equations may be inapplicable. Equations (1) and (2) may be used to determine C for these applications. The purchaser shall specify the C dimension when Tables 1 and I-1 data do not apply.

(b) For components in smaller sizes and lower schedule numbers, it may be necessary to deposit weld metal on the inside diameter (I.D.) or use thicker wall materials in order to machine the backing ring while maintaining required wall thickness. This condition may also arise when using material whose nominal dimensions indicate sufficient metal but whose actual I.D., considering tolerances, is large enough to require additional metal.

5 TOLERANCES

See Figures 2, 3, 5, and 6.

5.1 Dimension B

Values for the I.D. at the welding end [see dimension B , Figure 2, illustrations (a) and (b) and Figure 3, illustrations (a) and (b)] shall be as specified in the applicable standard or specification for the component.

5.2 Welding Bevels, Root Face, and Dimension C

Values of welding bevels, root face, and dimension C shall be as indicated in Figures 2 through 6.

Large diameter pipe and fittings with a relatively thin wall have a tendency to spring out-of-round after removal from the machining fixture. For this reason, the measured diameters may vary with orientation. A tolerance of +0.25 mm (+0.010 in.) applies to the average C diameter in Figures 2 and 3, illustrations (c) and (d). A tolerance of +0.25 mm, -1.02 mm (+0.010 in., -0.040 in.) applies to the average C diameter for Figures 5 and 6.

5.3 Dimension A

(17)

Unless otherwise specified, the tolerances for dimension A shall be as follows:

Size	Tolerance
DN \leq 40 (NPS \leq 1 ¹ / ₂)	\pm 0.4 mm (\pm 0.015 in.)
50 \leq DN \leq 125 (2 \leq NPS \leq 5)	+2.5 mm, -0.79 mm (+0.10 in., -0.031 in.)
DN \geq 150 (NPS \geq 6)	+4.0 mm, -0.79 mm (+0.16 in., -0.031 in.)

5.4 Wall Thickness

(17)

The maximum thickness at the end of the component is (a) greater of $t_{\min} + 4$ mm (0.16 in.) or $1.15t_{\min}$ when ordered on a minimum wall basis.

(b) greater of $t_{\min} + 4$ mm (0.16 in.) or 1.10 times the nominal wall thickness when ordered on a nominal wall basis. See ASME B36.10M and ASME B36.19M for a tabulation of nominal wall thicknesses.

The minimum thickness, t_{\min} , shall be as specified in the applicable standard or specification for the component (see Figure 1).

(17)

Figure 1 Maximum Envelope for Welding End Transitions

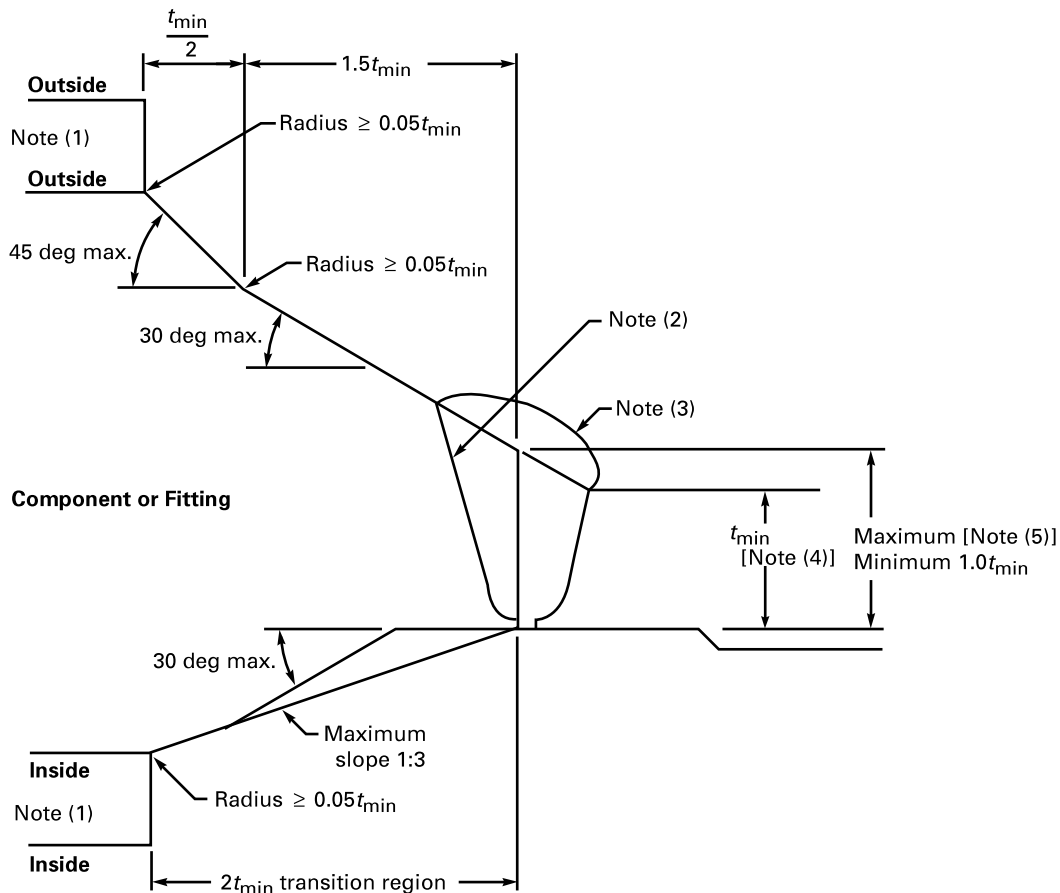

NOTES:

- (1) Where transitions using maximum slope do not intersect inside or outside surface, as shown by phantom outlines, maximum slopes shown or alternate radii shall be used.
- (2) Weld bevel shown is for illustration only.
- (3) The weld reinforcement permitted by applicable code may lie outside the maximum envelope.
- (4) The value of t_{min} is whichever of the following is applicable:
 - (a) the minimum ordered wall thickness of the pipe to include pipe that is purchased to a nominal wall thickness with an undertolerance other than 12.5%
 - (b) 0.875 times the nominal wall thickness of pipe ordered to a pipe schedule wall thickness that has an undertolerance of 12.5%
 - (c) the minimum ordered wall thickness of the cylindrical welding end of a component or fitting (or the thinner of the two) when the joint is between two components
- (5) The maximum thickness at the end of the components is
 - (a) the greater of $t_{min} + 4$ mm (0.16 in.) or $1.15t_{min}$ when ordered on a minimum wall basis
 - (b) the greater of $t_{min} + 4$ mm (0.16 in.) or 1.10 times the nominal wall thickness when ordered on a nominal basis (see ASME B36.10M and ASME B36.19M for a tabulation of nominal wall thicknesses)

Figure 2 Bevels for Wall Thickness Over 3 mm (0.12 in.) to 22 mm (0.88 in.), Inclusive

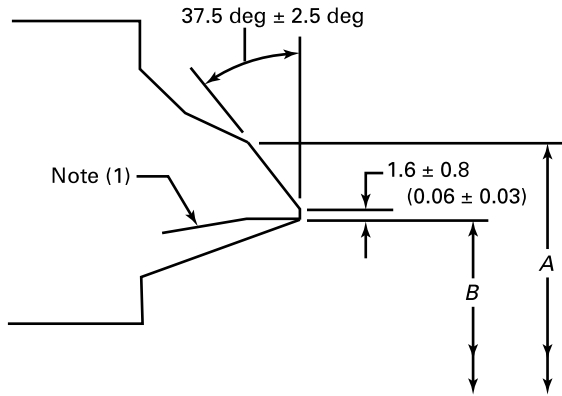

(a) Welding End Detail for Joint Without Backing Ring

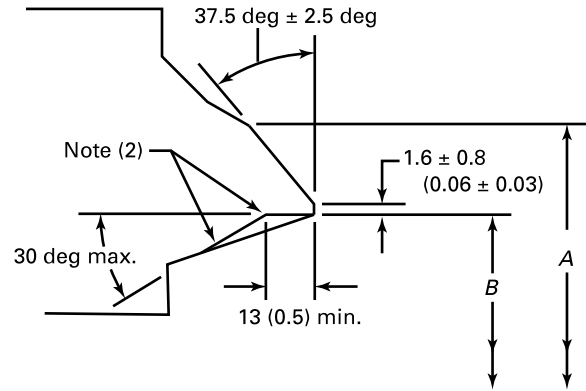

(b) Welding End Detail for Joint Using Split Rectangular Backing Ring

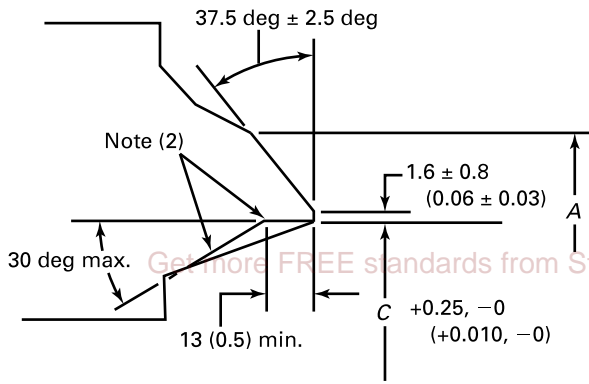

(c) Welding End Detail for Joint Using Continuous Rectangular Backing Ring

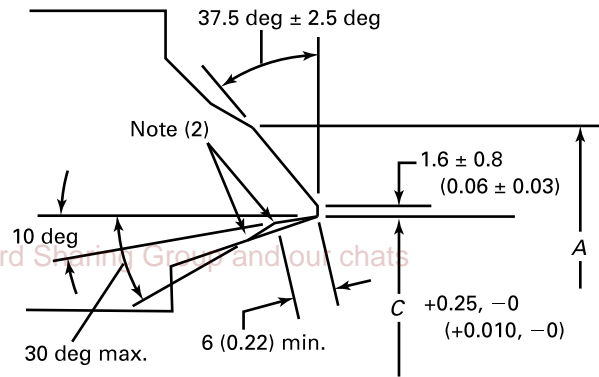

(d) Welding End Detail for Joint Using Continuous Tapered Backing Ring

GENERAL NOTES:

- (a) Broken lines denote maximum envelope for transitions from welding bevel and root face into body of component. See Figure 1 for details.
- (b) See section 5 for tolerances other than those given in these illustrations.
- (c) Purchase order must specify contour of any backing ring to be used.
- (d) Linear dimensions are in millimeters with inch values in parentheses.

NOTES:

- (1) Internal surface may be as-formed or machined for dimension B at root face. Contour within the envelope shall be in accordance with section 2.
- (2) Intersections should be slightly rounded.

Figure 3 Weld Bevel Details for Wall Thickness Over 22 mm (0.88 in.)

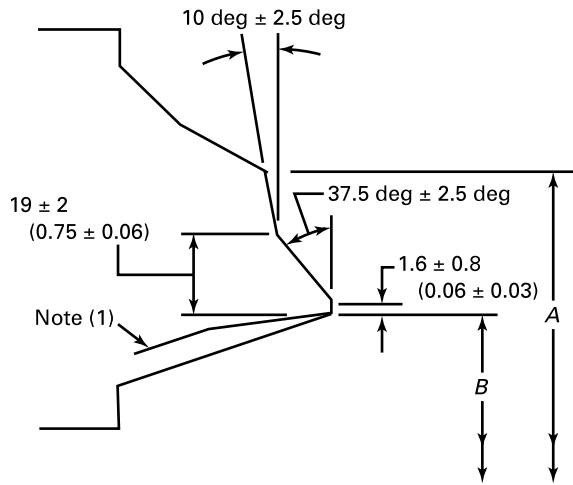

(a) Welding End Detail for Joint Without Backing Ring

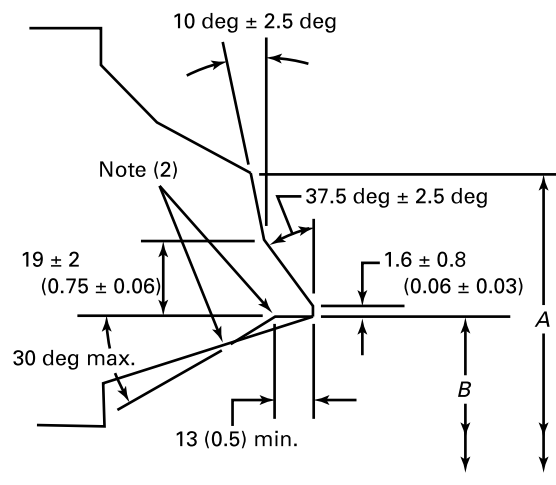

(b) Welding End Detail for Joint Using Split Rectangular Backing Ring

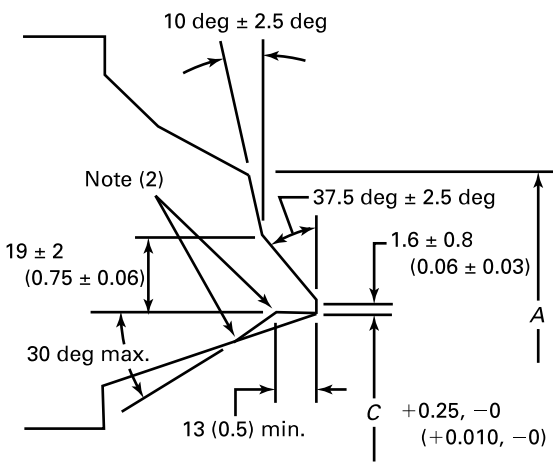

(c) Welding End Detail for Joint Using Continuous Rectangular Backing Ring

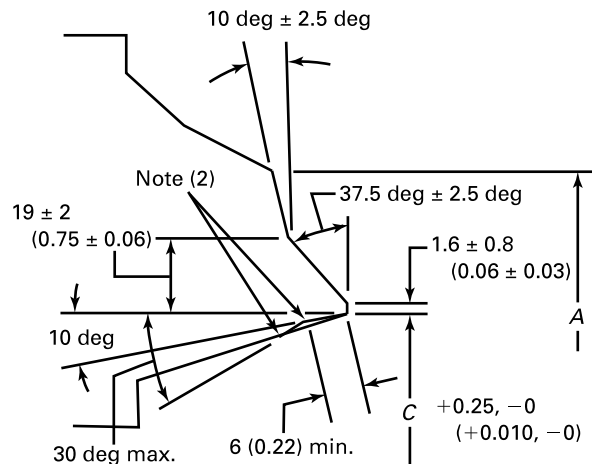

(d) Welding End Detail for Joint Using Continuous Tapered Backing Ring

GENERAL NOTES:

- (a) Broken lines denote maximum envelope for transitions from welding bevel and root face into body of component. See [Figure 1](#) for details.
- (b) See [section 5](#) for tolerances other than those given in these illustrations.
- (c) Purchase order must specify contour of any backing ring to be used.
- (d) Linear dimensions are in millimeters with inch values in parentheses.

NOTES:

- (1) Internal surface may be as-formed or machined for dimension *B* at root face. Contour within the envelope shall be in accordance with [section 2](#).
- (2) Intersections should be slightly rounded.

Figure 4 Weld Bevel Details for GTAW Root Pass [Wall Thickness Over 3 mm (0.12 in.) to 10 mm (0.38 in.), Inclusive]

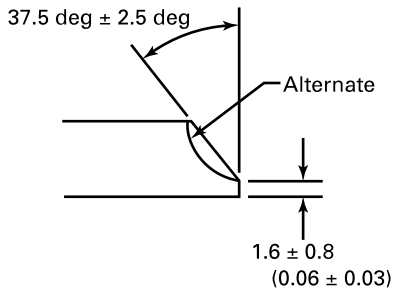

GENERAL NOTES:

- (a) This detail applies for gas tungsten arc welding (GTAW) of the root pass where nominal wall thickness is over 3 mm (0.12 in.) to 10 mm (0.38 in.), inclusive.
- (b) Linear dimensions are in millimeters with inch values in parentheses.

Figure 5 Weld Bevel Details for GTAW Root Pass [Wall Thickness Over 10 mm (0.38 in.) to 25 mm (1.0 in.), Inclusive]

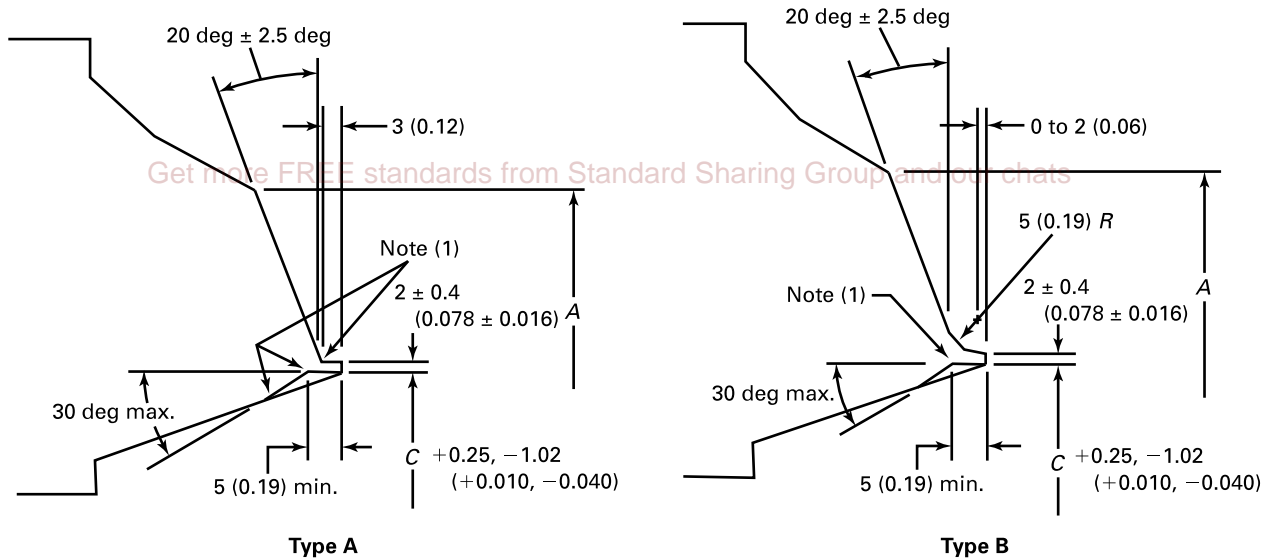

GENERAL NOTES:

- (a) This detail applies for gas tungsten arc welding (GTAW) of the root pass where nominal wall thickness is over 10 mm (0.38 in.) to 25 mm (1.0 in.), inclusive.
- (b) Broken lines denote maximum envelope for transitions from welding groove and land into body of component. See Figure 1 for details.
- (c) See section 5 for tolerances other than those given in these illustrations.
- (d) Linear dimensions are in millimeters with inch values in parentheses.

NOTE: (1) Inside corners should be slightly rounded.

Figure 6 Weld Bevel Details for GTAW Root Pass [Wall Thickness Over 25 mm (1.0 in.)]

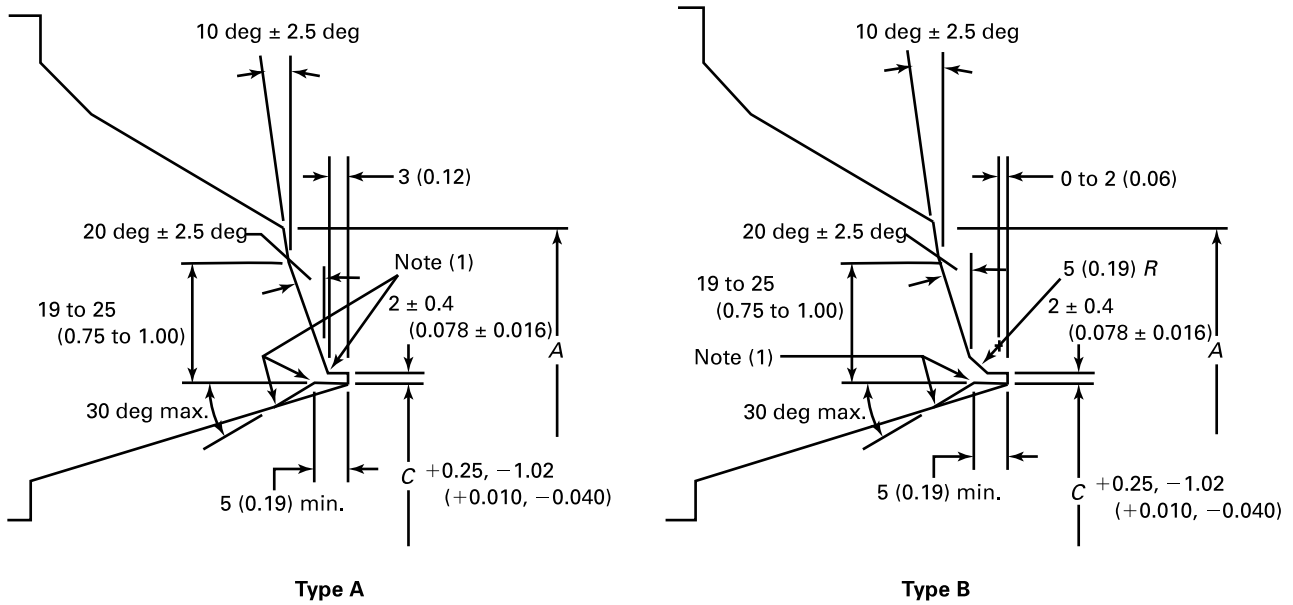

GENERAL NOTES:

- (a) This detail applies for gas tungsten arc welding (GTAW) of the root pass where nominal wall thickness is greater than 25 mm (1.0 in.).
- (b) Broken lines denote maximum envelope for transitions from welding groove and land into body of component. See Figure 1 for details.
- (c) See section 5 for tolerances other than those given in these illustrations.
- (d) Linear dimensions are in millimeters with inch values in parentheses.

NOTE: (1) Inside corners should be slightly rounded.

(17)

Table 1 Dimensions of Welding Ends, Metric (See Figures 1 Through 6)

Nominal Pipe Size (NPS)	Schedule No. [Note (1)]	O.D. at Welding Ends				
		Wrought or Fabricated Components, A	Cast Components, A	B	C [Note (3)]	t
		[Notes (1), (2)]	[Note (2)]			
1/2	80, 80S	21.3	23	13.84	14.12	3.73
	160	21.3	23	11.74	12.28	4.78
	XXS	21.3	23	6.36	7.58	7.47
3/4	80, 80S	26.7	28	18.88	19.21	3.91
	160	26.7	28	15.58	16.32	5.56
	XXS	26.7	28	11.06	12.36	7.82
1	40, 40S	33.4	35	26.64	26.84	3.38
	80, 80S	33.4	35	24.30	24.79	4.55
	160	33.4	35	20.70	21.64	6.35
	XXS	33.4	35	15.22	16.84	9.09
1 1/4	40, 40S	42.2	44	35.08	35.32	3.56
	80, 80S	42.2	44	32.50	33.06	4.85
	160	42.2	44	29.50	30.44	6.35
	XXS	42.2	44	22.80	24.58	9.70
1 1/2	40, 40S	48.3	50	40.94	41.21	3.68
	80, 80S	48.3	50	38.14	38.76	5.08
	160	48.3	50	34.02	35.16	7.14
	XXS	48.3	50	28.00	29.89	10.15
2	40, 40S	60.3	62	52.48	53.35	3.91
	80, 80S	60.3	62	49.22	50.50	5.54
	160	60.3	62	42.82	44.90	8.74
	XXS	60.3	62	38.16	40.82	11.07
2 1/2	30	73.0	75	63.50	63.60	4.78
	40, 40S	73.0	75	62.50	62.93	5.16
	80, 80S	73.0	75	59.00	59.69	7.01
	160	73.0	75	54.00	55.28	9.53
	XXS	73.0	75	45.00	47.43	14.02
3	30	88.9	91	79.50	79.50	4.78
	40, 40S	88.9	91	78.00	78.25	5.49
	80, 80S	88.9	91	73.50	74.53	7.62
	160	88.9	91	66.50	68.38	11.13
	XXS	88.9	91	58.50	61.19	15.24
3 1/2	30	101.6	105	92.00	92.20	4.78
	40, 40S	101.6	105	90.00	90.52	5.74
	80, 80S	101.6	105	85.50	86.42	8.08
4	30	114.3	117	104.50	104.90	4.78
	40, 40S	114.3	117	102.00	102.73	6.02

(17) **Table 1 Dimensions of Welding Ends, Metric (See Figures 1 Through 6) (Cont'd)**

Nominal Pipe Size (NPS)	Schedule No. [Note (1)]	O.D. at Welding Ends				
		Wrought or Fabricated Components, A	Cast Components, A	B	C [Note (3)]	t
		[Notes (1), (2)]	[Note (2)]			
	80, 80S	114.3	117	97.00	98.28	8.56
	120	114.3	117	92.00	93.78	11.13
	160	114.3	117	87.50	89.65	13.49
	XXS	114.3	117	80.00	83.30	17.12
5	40, 40S	141.3	144	128.00	128.80	6.55
	80, 80S	141.3	144	122.00	123.58	9.53
	120	141.3	144	116.00	118.04	12.70
	160	141.3	144	109.50	112.47	15.88
	XXS	141.3	144	103.00	106.92	19.05
6	40, 40S	168.3	172	154.00	154.82	7.11
	80, 80S	168.3	172	146.50	148.06	10.97
	120	168.3	172	140.00	142.29	14.27
	160	168.3	172	132.00	135.31	18.26
	XXS	168.3	172	124.50	128.85	21.95
8	20	219.1	223	206.50	206.95	6.35
	30	219.1	223	205.00	205.74	7.04
	40, 40S	219.1	223	203.00	203.75	8.18
	60	219.1	223	198.50	200.02	10.31
	80, 80S	219.1	223	193.50	195.84	12.70
	100	219.1	223	189.00	191.65	15.09
	120	219.1	223	182.50	186.11	18.26
	140	219.1	223	178.00	181.98	20.62
	XXS	219.1	223	174.50	179.16	22.23
	160	219.1	223	173.00	177.79	23.01
10	20	273.0	278	260.50	260.85	6.35
	30	273.0	278	257.50	258.31	7.80
	40, 40S	273.0	278	254.50	255.74	9.27
	60, 80S	273.0	278	247.50	249.74	12.70
	80	273.0	278	243.00	245.55	15.09
	100	273.0	278	236.50	240.01	18.26
	120	273.0	278	230.00	234.44	21.44
	140	273.0	278	222.00	227.51	25.40
	160	273.0	278	216.00	221.95	28.58
12	20	323.8	329	311.00	311.65	6.35
	30	323.8	329	307.00	308.10	8.38
	STD, 40S	323.8	329	305.00	306.08	9.53
	40	323.8	329	303.00	304.72	10.31
	XS, 80S	323.8	329	298.50	300.54	12.70

(17)

Table 1 Dimensions of Welding Ends, Metric (See Figures 1 Through 6) (Cont'd)

Nominal Pipe Size (NPS)	Schedule No. [Note (1)]	O.D. at Welding Ends				
		Wrought or Fabricated Components, A [Notes (1), (2)]	Cast Components, A [Note (2)]	B	C [Note (3)]	t
14	60	323.8	329	295.00	297.79	14.27
	80	323.8	329	289.00	292.17	17.48
	100	323.8	329	281.00	285.24	21.44
	120	323.8	329	273.00	278.31	25.40
	140	323.8	329	266.50	272.75	28.58
	160	323.8	329	257.00	264.45	33.32
	20	355.6	362	340.00	340.70	7.92
	STD, 40S	355.6	362	336.50	337.88	9.53
	40	355.6	362	333.50	335.08	11.13
	XS, 80S	355.6	362	330.00	332.34	12.70
	60	355.6	362	325.50	328.15	15.09
	80	355.6	362	317.50	321.22	19.05
	100	355.6	362	308.00	312.86	23.83
	120	355.6	362	300.00	305.93	27.79
	140	355.6	362	292.00	299.00	31.75
	160	355.6	362	284.00	292.07	35.71
16	20	406.4	413	390.50	391.50	7.92
	STD, 40S	406.4	413	387.50	388.68	9.53
	40, 80S	406.4	413	381.00	383.14	12.70
	60	406.4	413	373.00	376.21	16.66
	80	406.4	413	363.50	367.84	21.44
	100	406.4	413	354.00	359.53	26.19
	120	406.4	413	344.50	351.18	30.96
	140	406.4	413	333.50	341.43	36.53
	160	406.4	413	325.50	334.50	40.49
	18	20	457.2	464	441.50	442.30
30		457.2	464	435.00	436.68	11.13
STD, 40S		457.2	464	438.00	439.48	9.53
XS, 80S		457.2	464	432.00	433.94	12.70
40		457.2	464	428.50	431.19	14.27
60		457.2	464	419.00	422.82	19.05
80		457.2	464	409.50	414.46	23.83
100		457.2	464	398.50	404.78	29.36
120		457.2	464	387.50	395.03	34.93
140		457.2	464	378.00	386.77	39.67
160		457.2	464	366.50	376.99	45.24

Get more FREE standards from Standard Sharing Group and WhatsApp

(17) **Table 1 Dimensions of Welding Ends, Metric (See Figures 1 Through 6) (Cont'd)**

Nominal Pipe Size (NPS)	Schedule No. [Note (1)]	O.D. at Welding Ends					<i>t</i>
		Wrought or Fabricated Components,		Cast Components,		<i>C</i> [Note (3)]	
		<i>A</i> [Notes (1), (2)]	<i>A</i> [Note (2)]	<i>B</i>			
20	STD, 40S	508.0	516	489.00	490.28	9.53	
	XS, 80S	508.0	516	482.50	484.74	12.70	
	40	508.0	516	478.00	480.55	15.09	
	60	508.0	516	467.00	470.88	20.62	
	80	508.0	516	455.50	461.13	26.19	
	100	508.0	516	443.00	450.02	32.54	
	120	508.0	516	432.00	440.29	38.10	
	140	508.0	516	419.00	429.17	44.45	
	160	508.0	516	408.00	419.44	50.01	
	22	STD	558.8	567	539.00	541.08	9.53
XS		558.8	567	533.00	535.54	12.70	
60		558.8	567	514.00	518.86	22.23	
80		558.8	567	501.00	507.75	28.58	
100		558.8	567	488.50	496.63	34.93	
120		558.8	567	476.00	485.52	41.28	
140		558.8	567	463.00	474.41	47.63	
160		558.8	567	450.50	463.30	53.98	
24	STD, 40S	609.6	619	590.50	591.88	9.53	
	XS, 80S	609.6	619	584.00	586.34	12.70	
	30	609.6	619	581.00	583.59	14.27	
	40	609.6	619	574.50	577.97	17.48	
	60	609.6	619	560.50	565.49	24.61	
	80	609.6	619	547.50	554.38	30.96	
	100	609.6	619	532.00	540.49	38.89	
	120	609.6	619	517.50	528.03	46.02	
	140	609.6	619	505.00	516.91	52.37	
	160	609.6	619	490.50	504.37	59.54	
26	10	660.4	670	645.50	645.50	7.92	
	STD	660.4	670	641.34	642.68	9.53	
	20	660.4	670	635.00	637.14	12.70	
28	10	711.2	721	695.50	696.30	7.92	
	STD	711.2	721	692.14	693.48	9.53	
	20	711.2	721	686.00	687.94	12.70	
	30	711.2	721	679.50	682.37	15.88	
30	10	762.0	772	746.00	747.10	7.92	
	STD	762.0	772	742.94	744.28	9.53	
	20	762.0	772	736.50	738.74	12.70	
	30	762.0	772	730.00	733.17	15.88	

(17)

Table 1 Dimensions of Welding Ends, Metric (See Figures 1 Through 6) (Cont'd)

Nominal Pipe Size (NPS)	Schedule No. [Note (1)]	O.D. at Welding Ends					<i>t</i>
		Wrought or Fabricated Components, <i>A</i> [Notes (1), (2)]	Cast Components, <i>A</i> [Note (2)]	<i>B</i>	<i>C</i> [Note (3)]		
32	10	812.8	825	797.00	797.90	7.92	
	STD	812.8	825	793.74	795.08	9.53	
	20	812.8	825	787.50	789.54	12.70	
	30	812.8	825	781.00	783.97	15.88	
	40	812.8	825	778.00	781.17	17.48	
34	10	863.6	876	848.00	848.70	7.92	
	STD	863.6	876	844.54	845.88	9.53	
	20	863.6	876	838.00	840.34	12.70	
	30	863.6	876	832.00	834.77	15.88	
	40	863.6	876	828.50	831.97	17.48	
36	10	914.4	927	898.50	899.50	7.92	
	STD	914.4	927	895.34	896.68	9.53	
	20	914.4	927	889.00	891.14	12.70	
	30	914.4	927	882.50	885.57	15.88	
	40	914.4	927	876.50	880.02	19.05	
38	STD	965.2	978	946.00	947.48	9.53	
	XS	965.2	978	940.00	941.94	12.70	
40	STD	1 016.0	1 029	997.00	998.28	9.53	
	XS	1 016.0	1 029	990.50	992.74	12.70	
42	STD	1 066.8	1 079	1 047.50	1 049.08	9.53	
	XS	1 066.8	1 079	1 041.50	1 043.54	12.70	
44	STD	1 117.6	1 130	1 098.50	1 099.88	9.53	
	XS	1 117.6	1 130	1 092.00	1 094.34	12.70	
46	STD	1 168.4	1 181	1 149.50	1 150.68	9.53	
	XS	1 168.4	1 181	1 143.00	1 145.14	12.70	
48	STD	1 219.2	1 232	1 200.00	1 201.48	9.53	
	XS	1 219.2	1 232	1 194.00	1 195.94	12.70	
52	...	1 321	1 334	1 301.94	1 304.22	9.53	
	...	1 321	1 334	1 295.60	1 298.67	12.70	
	...	1 321	1 334	1 289.24	1 293.10	15.88	
	...	1 321	1 334	1 282.90	1 287.56	19.05	
	...	1 321	1 334	1 276.54	1 281.89	22.23	
	...	1 321	1 334	1 270.20	1 276.44	25.40	

Get more FREE standards from Standard Sharing Group and our chats

(17) **Table 1 Dimensions of Welding Ends, Metric (See Figures 1 Through 6) (Cont'd)**

Nominal Pipe Size (NPS)	Schedule No. [Note (1)]	O.D. at Welding Ends				
		Wrought or Fabricated Components, <i>A</i>	Cast Components, <i>A</i>	<i>B</i>	<i>C</i> [Note (3)]	<i>t</i>
		[Notes (1), (2)]	[Note (2)]			
56	...	1 422	1 436	1 402.94	1 405.22	9.53
	...	1 422	1 436	1 396.60	1 399.67	12.70
	...	1 422	1 436	1 390.24	1 394.10	15.88
	...	1 422	1 436	1 383.90	1 388.56	19.05
	...	1 422	1 436	1 377.54	1 382.89	22.23
	...	1 422	1 436	1 371.20	1 377.44	25.40
60	...	1 524	1 540	1 504.94	1 507.22	9.53
	...	1 524	1 540	1 498.60	1 501.67	12.70
	...	1 524	1 540	1 492.24	1 496.10	15.88
	...	1 524	1 540	1 485.90	1 490.56	19.05
	...	1 524	1 540	1 479.54	1 484.89	22.23
	...	1 524	1 540	1 473.20	1 479.44	25.40

GENERAL NOTES:

- (a) Dimensions are in millimeters.
 (b) See section 5 for tolerances.

NOTES:

- (1) Data are from ASME B36.10M and ASME B36.19M or a more precise rounding of the inch dimensions from Table 1-1. Letter designations signify
 (a) STD = standard wall thickness
 (b) XS = extra-strong wall thickness
 (c) XXS = double extra-strong wall thickness
 (2) See para. 3.3.
 (3) Internal machining for continuous backing rings for connecting pipe having a wall thickness ≤ 3.17 mm (0.125 in.) is not contemplated (see para. 3.1). See para. 4.2 for *C* dimension for sizes or schedules not listed.

MANDATORY APPENDIX I INCH TABLE

This Mandatory Appendix provides a table ([Table I-1](#)) of the standard inch dimensions for fittings.

Get more FREE standards from Standard Sharing Group and our chats

(17)

Table I-1 Dimensions of Welding Ends, U.S. Customary (See Figures 1 Through 6)

Nominal Pipe Size (NPS)	Schedule No. [Note (1)]	O.D. at Welding Ends				
		Wrought or Fabricated Components, A	Cast Components, A	B	C	t
		[Notes (1), (2)]	[Note (2)]			
1/2	80, 80S	0.840	0.90	0.546	0.558	0.147
	160	0.840	0.90	0.464	0.486	0.188
	XXS	0.840	0.90	0.252	0.300	0.294
3/4	80, 80S	1.050	1.11	0.742	0.756	0.154
	160	1.050	1.11	0.612	0.642	0.219
	XXS	1.050	1.11	0.434	0.486	0.308
1	40, 40S	1.315	1.37	1.049	1.057	0.133
	80, 80S	1.315	1.37	0.957	0.977	0.179
	160	1.315	1.37	0.815	0.852	0.250
	XXS	1.315	1.37	0.599	0.664	0.358
1 1/4	40, 40S	1.660	1.74	1.380	1.390	0.140
	80, 80S	1.660	1.74	1.278	1.301	0.191
	160	1.660	1.74	1.160	1.198	0.250
	XXS	1.660	1.74	0.896	0.966	0.382
1 1/2	40, 40S	1.900	1.98	1.610	1.621	0.145
	80, 80S	1.900	1.98	1.500	1.525	0.200
	160	1.900	1.98	1.338	1.383	0.281
	XXS	1.900	1.98	1.100	1.175	0.400
2	40, 40S	2.375	2.46	2.067	2.064	0.154
	80, 80S	2.375	2.46	1.939	1.952	0.218
	160	2.375	2.46	1.687	1.732	0.344
	XXS	2.375	2.46	1.503	1.571	0.436
2 1/2	30	2.875	2.96	2.499	2.505	0.188
	40, 40S	2.875	2.96	2.469	2.479	0.203
	80, 80S	2.875	2.96	2.323	2.351	0.276
	160	2.875	2.96	2.125	2.178	0.375
	XXS	2.875	2.96	1.771	1.868	0.552
3	30	3.500	3.59	3.124	3.130	0.188
	40, 40S	3.500	3.59	3.068	3.081	0.216
	80, 80S	3.500	3.59	2.900	2.934	0.300
	160	3.500	3.59	2.624	2.692	0.438
	XXS	3.500	3.59	2.300	2.409	0.600
3 1/2	30	4.000	4.12	3.624	3.630	0.188
	40, 40S	4.000	4.12	3.548	3.564	0.226
	80, 80S	4.000	4.12	3.364	3.402	0.318
4	30	4.500	4.62	4.124	4.130	0.188
	40, 40S	4.500	4.62	4.026	4.044	0.237

(17) **Table I-1 Dimensions of Welding Ends, U.S. Customary (See Figures 1 Through 6) (Cont'd)**

Nominal Pipe Size (NPS)	Schedule No. [Note (1)]	O.D. at Welding Ends					
		Wrought or Fabricated Components, A	Cast Components, A	B	C	t	
		[Notes (1), (2)]	[Note (2)]				[Note (3)]
	80, 80S	4.500	4.62	3.826	3.869	0.337	
	120	4.500	4.62	3.624	3.692	0.438	
	160	4.500	4.62	3.438	3.530	0.531	
	XXS	4.500	4.62	3.152	3.279	0.674	
5	40, 40S	5.563	5.69	5.047	5.070	0.258	
	80, 80S	5.563	5.69	4.813	4.866	0.375	
	120	5.563	5.69	4.563	4.647	0.500	
	160	5.563	5.69	4.313	4.428	0.625	
	XXS	5.563	5.69	4.063	4.209	0.750	
6	40, 40S	6.625	6.78	6.065	6.094	0.280	
	80, 80S	6.625	6.78	5.761	5.828	0.432	
	120	6.625	6.78	5.501	5.600	0.562	
	160	6.625	6.78	5.187	5.326	0.719	
	XXS	6.625	6.78	4.897	5.072	0.864	
8	20	8.625	8.78	8.125	8.146	0.250	
	30	8.625	8.78	8.071	8.099	0.277	
	40, 40S	8.625	8.78	7.981	8.020	0.322	
	60	8.625	8.78	7.813	7.873	0.406	
	80, 80S	8.625	8.78	7.625	7.709	0.500	
	100	8.625	8.78	7.437	7.544	0.594	
	120	8.625	8.78	7.187	7.326	0.719	
	140	8.625	8.78	7.001	7.163	0.812	
	XXS	8.625	8.78	6.875	7.053	0.875	
	160	8.625	8.78	6.813	6.998	0.906	
	10	20	10.750	10.94	10.250	10.272	0.250
		30	10.750	10.94	10.136	10.172	0.307
40, 40S		10.750	10.94	10.020	10.070	0.365	
60, 80S		10.750	10.94	9.750	9.834	0.500	
80		10.750	10.94	9.562	9.670	0.594	
100		10.750	10.94	9.312	9.451	0.719	
120		10.750	10.94	9.062	9.232	0.844	
140		10.750	10.94	8.750	8.959	1.000	
160		10.750	10.94	8.500	8.740	1.125	
12		20	12.750	12.97	12.250	12.272	0.250
	30	12.750	12.97	12.090	12.132	0.330	
	STD, 40S	12.750	12.97	12.000	12.053	0.375	
	40	12.750	12.97	11.938	11.999	0.406	
	XS, 80S	12.750	12.97	11.750	11.834	0.500	

(17) **Table I-1 Dimensions of Welding Ends, U.S. Customary (See Figures 1 Through 6) (Cont'd)**

Nominal Pipe Size (NPS)	Schedule No. [Note (1)]	O.D. at Welding Ends					
		Wrought or Fabricated Components, A	Cast Components, A	B	C	t	
		[Notes (1), (2)]	[Note (2)]				[Note (3)]
	60	12.750	12.97	11.626	11.725	0.562	
	80	12.750	12.97	11.374	11.505	0.688	
	100	12.750	12.97	11.062	11.232	0.844	
	120	12.750	12.97	10.750	10.959	1.000	
	140	12.750	12.97	10.500	10.740	1.125	
	160	12.750	12.97	10.126	10.413	1.312	
	14	20	14.000	14.25	13.376	13.413	0.312
STD, 40S		14.000	14.25	13.250	13.303	0.375	
40		14.000	14.25	13.124	13.192	0.438	
XS, 80S		14.000	14.25	13.000	13.084	0.500	
60		14.000	14.25	12.812	12.920	0.594	
80		14.000	14.25	12.500	12.646	0.750	
100		14.000	14.25	12.124	12.318	0.938	
120		14.000	14.25	11.812	12.044	1.094	
140		14.000	14.25	11.500	11.771	1.250	
160		14.000	14.25	11.188	11.498	1.406	
16		20	16.000	16.25	15.376	15.413	0.312
	STD, 40S	16.000	16.25	15.250	15.303	0.375	
	40, 80S	16.000	16.25	15.000	15.084	0.500	
	60	16.000	16.25	14.688	14.811	0.656	
	80	16.000	16.25	14.312	14.482	0.844	
	100	16.000	16.25	13.938	14.155	1.031	
	120	16.000	16.25	13.562	13.826	1.219	
	140	16.000	16.25	13.124	13.442	1.438	
	160	16.000	16.25	12.812	13.170	1.594	
	18	20	18.000	18.28	17.376	17.413	0.312
		30	18.000	18.28	17.124	17.192	0.438
STD, 40S		18.000	18.28	17.250	17.303	0.375	
XS, 80S		18.000	18.28	17.000	17.084	0.500	
40		18.000	18.28	16.876	16.975	0.562	
60		18.000	18.28	16.500	16.646	0.750	
80		18.000	18.28	16.124	16.318	0.938	
100		18.000	18.28	15.688	15.936	1.156	
120		18.000	18.28	15.250	15.553	1.375	
140		18.000	18.28	14.876	15.225	1.562	
160		18.000	18.28	14.438	14.842	1.781	

(17) **Table I-1 Dimensions of Welding Ends, U.S. Customary (See Figures 1 Through 6) (Cont'd)**

Nominal Pipe Size (NPS)	Schedule No. [Note (1)]	O.D. at Welding Ends					<i>t</i>
		Wrought or Fabricated Components, <i>A</i>	Cast Components, <i>A</i>	<i>B</i>	<i>C</i>		
		[Notes (1), (2)]	[Note (2)]			[Note (3)]	
20	STD, 40S	20.000	20.31	19.250	19.303	0.375	
	XS, 80S	20.000	20.31	19.000	19.084	0.500	
	40	20.000	20.31	18.812	18.920	0.594	
	20.000	20.31	18.376	18.538	0.812		
	80	20.000	20.31	17.938	18.155	1.031	
	100	20.000	20.31	17.438	17.717	1.281	
	120	20.000	20.31	17.000	17.334	1.500	
60	140	20.000	20.31	16.500	16.896	1.750	
	160	20.000	20.31	16.062	16.513	1.969	
	22	STD	22.000	22.34	21.250	21.303	0.375
		XS	22.000	22.34	21.000	21.084	0.500
		60	22.000	22.34	20.250	20.428	0.875
		80	22.000	22.34	19.750	19.990	1.125
		100	22.000	22.34	19.250	19.553	1.375
120		22.000	22.34	18.750	19.115	1.625	
140		22.000	22.34	18.250	18.678	1.875	
160	22.000	22.34	17.750	18.240	2.125		
24	STD, 40S	24.000	24.38	23.250	23.303	0.375	
	XS, 80S	24.000	24.38	23.000	23.084	0.500	
	30	24.000	24.38	22.876	22.975	0.562	
	40	24.000	24.38	22.624	22.755	0.688	
	60	24.000	24.38	22.062	22.263	0.969	
	80	24.000	24.38	21.562	21.826	1.219	
	100	24.000	24.38	20.938	21.280	1.531	
	120	24.000	24.38	20.376	20.788	1.812	
	140	24.000	24.38	19.876	20.350	2.062	
	160	24.000	24.38	19.312	19.857	2.344	
26	10	26.000	26.38	25.376	25.413	0.312	
	STD	26.000	26.38	25.250	25.303	0.375	
	20	26.000	26.38	25.000	25.084	0.500	
28	10	28.000	28.38	27.376	27.413	0.312	
	STD	28.000	28.38	27.250	27.303	0.375	
	20	28.000	28.38	27.000	27.084	0.500	
	30	28.000	28.38	26.750	26.865	0.625	
30	10	30.000	30.38	29.376	29.413	0.312	
	STD	30.000	30.38	29.250	29.303	0.375	
	20	30.000	30.38	29.000	29.084	0.500	
	30	30.000	30.38	28.750	28.865	0.625	

(17) **Table I-1 Dimensions of Welding Ends, U.S. Customary (See Figures 1 Through 6) (Cont'd)**

Nominal Pipe Size (NPS)	Schedule No. [Note (1)]	O.D. at Welding Ends				
		Wrought or Fabricated Components, A	Cast Components, A	B	C	t
		[Notes (1), (2)]	[Note (2)]			
32	10	32.000	32.50	31.376	31.413	0.312
	STD	32.000	32.50	31.250	31.303	0.375
	20	32.000	32.50	31.000	31.084	0.500
	30	32.000	32.50	30.750	30.865	0.625
	40	32.000	32.50	30.624	30.755	0.688
34	10	34.000	34.50	33.376	33.413	0.312
	STD	34.000	34.50	33.250	33.303	0.375
	20	34.000	34.50	33.000	33.084	0.500
	30	34.000	34.50	32.750	32.865	0.625
	40	34.000	34.50	32.624	32.755	0.688
36	10	36.000	36.50	35.376	35.413	0.312
	STD	36.000	36.50	35.250	35.303	0.375
	20	36.000	36.50	35.000	35.084	0.500
	30	36.000	36.50	34.750	34.865	0.625
	40	36.000	36.50	34.500	34.646	0.750
38	STD	38.000	38.50	37.250	37.303	0.375
	XS	38.000	38.50	36.000	37.084	0.500
40	STD	40.000	40.50	39.250	39.303	0.375
	XS	40.000	40.50	39.000	39.084	0.500
42	STD	42.000	42.50	41.250	41.303	0.375
	XS	42.000	42.50	41.000	41.084	0.500
44	STD	44.000	44.50	43.250	43.303	0.375
	XS	44.000	44.50	43.000	43.084	0.500
46	STD	46.000	46.50	45.250	45.303	0.375
	XS	46.000	46.50	45.000	45.084	0.500
48	STD	48.000	48.50	47.250	47.303	0.375
	XS	48.000	48.50	47.000	47.084	0.500
52	...	52.000	52.50	51.250	51.303	0.375
	...	52.000	52.50	51.000	51.084	0.500
	...	52.000	52.50	50.750	50.865	0.625
	...	52.000	52.50	50.500	50.646	0.750
	...	52.000	52.50	50.250	50.428	0.875
	...	52.000	52.50	50.000	50.209	1.000

(17) **Table I-1 Dimensions of Welding Ends, U.S. Customary (See Figures 1 Through 6) (Cont'd)**

Nominal Pipe Size (NPS)	Schedule No. [Note (1)]	O.D. at Welding Ends					<i>t</i>
		Wrought or Fabricated Components, <i>A</i>	Cast Components, <i>A</i>	<i>B</i>	<i>C</i> [Note (3)]		
		[Notes (1), (2)]	[Note (2)]				
56	...	56.000	56.56	55.250	55.303	0.375	
	...	56.000	56.56	55.000	55.084	0.500	
	...	56.000	56.56	54.750	54.865	0.625	
	...	56.000	56.56	54.500	54.646	0.750	
	...	56.000	56.56	54.250	54.428	0.875	
	...	56.000	56.56	54.000	54.209	1.000	
60	...	60.000	60.62	59.250	59.303	0.375	
	...	60.000	60.62	59.000	59.084	0.500	
	...	60.000	60.62	58.750	58.865	0.625	
	...	60.000	60.62	58.500	58.646	0.750	
	...	60.000	60.62	58.250	58.428	0.875	
	...	60.000	60.62	58.000	58.209	1.000	

GENERAL NOTES:

- (a) Dimensions are in inches.
- (b) See section 5 for tolerances.

NOTES:

- (1) Data are from ASME B36.10M and ASME B36.19M. Letter designations signify
 - (a) STD = standard wall thickness
 - (b) XS = extra-strong wall thickness
 - (c) XXS = double extra-strong wall thickness
- (2) See para. 3.3.
- (3) Internal machining for continuous backing rings for connecting pipe having a wall thickness ≤ 3.17 mm (0.125 in.) is not contemplated (see para. 3.1). See para. 4.2 for *C* dimension for sizes or schedules not listed.

MANDATORY APPENDIX II REFERENCES

(17)

The following is a list of publications referenced in this Standard. Unless otherwise specified, the latest edition of ASME publications shall apply.

ASME B16.5, Pipe Flanges and Flanged Fittings

ASME B16.9, Factory-Made Wrought Butt welding Fittings

ASME B16.47, Large Diameter Steel Flanges

ASME B36.10M, Welded and Seamless Wrought Steel Pipe

ASME B36.19M, Stainless Steel Pipe

Publisher: The American Society of Mechanical Engineers (ASME), Two Park Avenue, New York, NY 10016-5990 (www.asme.org)

ASTM A106/A106M-15, Specification for Seamless Carbon Steel Pipe for High-Temperature Service

ASTM A335/A335M-15, Specification for Seamless Ferritic Alloy Steel Pipe for High-Temperature Service

ASTM E29-13, Standard Practice for Using Significant Digits in Test Data to Determine Conformance With Specifications

Publisher: American Society for Testing and Materials (ASTM International), 100 Barr Harbor Drive, P.O. Box C700, West Conshohocken, PA 19428-2959 (www.astm.org)

ISO 9000-2015, Quality management systems — Fundamentals and vocabulary¹

ISO 9001-2015, Quality management systems — Requirements¹

ISO 9004-2009, Managing for the sustained success of an organization — A quality management approach¹

Publisher: International Organization for Standardization (ISO), Central Secretariat, Chemin de Blandonnet 8, Case Postale 401, 1214 Vernier, Geneva, Switzerland (www.iso.org)

¹ May also be obtained from American National Standards Institute (ANSI), 25 West 43rd Street, New York, NY 10036.

NONMANDATORY APPENDIX A QUALITY SYSTEM PROGRAM

The products manufactured in accordance with this Standard shall be produced under a quality system program following the principles of an appropriate standard from the ISO 9000 series.¹ A determination of the need for registration and/or certification of the product manufacturer's quality system program by an independent organization shall be the responsibility of the manufacturer. The detailed documentation demon-

strating program compliance shall be available to the purchaser at the manufacturer's facility. A written summary description of the program utilized by the product manufacturer shall be available to the purchaser upon request. The product manufacturer is defined as the entity whose name or trademark appears on the product in accordance with the marking or identification requirements of this Standard.

Get more FREE standards from Standard Sharing Group and our chats

¹The series is also available from the American National Standards Institute (ANSI) and the American Society for Quality (ASQ) as American National Standards that are identified by the prefix "Q," replacing the prefix "ISO." Each standard of the series is listed under References in Mandatory Appendix II.

INTENTIONALLY LEFT BLANK

B16 AMERICAN NATIONAL STANDARDS FOR PIPING, PIPE FLANGES, FITTINGS, AND VALVES

B16.1-2015	Gray Iron Pipe Flanges and Flanged Fittings (Classes 25, 125, and 250)
B16.3-2016	Malleable Iron Threaded Fittings: Classes 150 and 300
B16.4-2016	Gray Iron Threaded Fittings: Classes 125 and 250
B16.5-2017	Pipe Flanges and Flanged Fittings NPS ½ Through NPS 24 Metric/Inch Standard
B16.9-2012	Factory-Made Wrought Butt welding Fittings
B16.10-2017	Face-to-Face and End-to-End Dimensions of Valves
B16.11-2016	Forged Fittings, Socket-Welding and Threaded
B16.12-2009 (R2014)	Cast Iron Threaded Drainage Fittings
B16.14-2013	Ferrous Pipe Plugs, Bushings, and Locknuts With Pipe Threads
B16.15-2013	Cast Copper Alloy Threaded Fittings
B16.18-2012	Cast Copper Alloy Solder Joint Pressure Fittings
B16.20-2017	Metallic Gaskets for Pipe Flanges
B16.21-2016	Nonmetallic Flat Gaskets for Pipe Flanges
B16.22-2013	Wrought Copper and Copper Alloy Solder-Joint Pressure Fittings
B16.23-2016	Cast Copper Alloy Solder Joint Drainage Fittings: DWV
B16.24-2016	Cast Copper Alloy Pipe Flanges, Flanged Fittings, and Valves: Classes 150, 300, 600, 900, 1500, and 2500
B16.25-2017	Butt welding Ends
B16.26-2013	Cast Copper Alloy Fittings for Flared Copper Tubes
B16.29-2017	Wrought Copper and Wrought Copper Alloy Solder-Joint Drainage Fittings — DWV
B16.33-2012	Manually Operated Metallic Gas Valves for Use in Gas Piping Systems Up to 175 psi (Sizes NPS ½ Through NPS 2)
B16.34-2017	Valves — Flanged, Threaded, and Welding End
B16.36-2015	Orifice Flanges
B16.38-2012	Large Metallic Valves for Gas Distribution: Manually Operated, NPS 2½ (DN 65) to NPS 12 (DN 300), 125 psig (8.6 bar) Maximum
B16.39-2014	Malleable Iron Threaded Pipe Unions: Classes 150, 250, and 300
B16.40-2013	Manually Operated Thermoplastic Gas Shutoffs and Valves in Gas Distribution Systems
B16.42-2016	Ductile Iron Pipe Flanges and Flanged Fittings: Classes 150 and 300
B16.44-2012	Manually Operated Metallic Gas Valves for Use in Aboveground Piping Systems Up to 5 psi
B16.47-2017	Large Diameter Steel Flanges NPS 26 Through NPS 60 Metric/Inch Standard
B16.48-2015	Line Blanks
B16.49-2017	Factory-Made, Wrought Steel, Butt welding Induction Bends for Transportation and Distribution Systems
B16.50-2013	Wrought Copper and Copper Alloy Braze-Joint Pressure Fittings
B16.51-2013	Copper and Copper Alloy Press-Connect Pressure Fittings

The ASME Publications Catalog shows a complete list of all the Standards published by the Society. For a complimentary catalog, or the latest information about our publications, call 1-800-THE-ASME (1-800-843-2763).

ASME Services

ASME is committed to developing and delivering technical information. At ASME's Customer Care, we make every effort to answer your questions and expedite your orders. Our representatives are ready to assist you in the following areas:

ASME Press	Member Services & Benefits	Public Information
<i>Codes & Standards</i>	Other ASME Programs	Self-Study Courses
Credit Card Orders	Payment Inquiries	Shipping Information
IMEchE Publications	Professional Development	Subscriptions/Journals/Magazines
Meetings & Conferences	Short Courses	Symposia Volumes
Member Dues Status	Publications	Technical Papers

How can you reach us? It's easier than ever!

There are four options for making inquiries* or placing orders. Simply mail, phone, fax, or E-mail us and a Customer Care representative will handle your request.

<i>Mail</i>	<i>Call Toll Free</i>	<i>Fax—24 hours</i>	<i>E-Mail—24 hours</i>
ASME	US & Canada: 800-THE-ASME	973-882-1717	customercare@asme.org
150 Clove Road, 6th Floor	(800-843-2763)	973-882-5155	
Little Falls, New Jersey	Mexico: 95-800-THE-ASME		
07424-2139	(95-800-843-2763)		

*Customer Care staff are not permitted to answer inquiries about the technical content of this code or standard. Information as to whether or not technical inquiries are issued to this code or standard is shown on the copyright page. All technical inquiries must be submitted in writing to the staff secretary. Additional procedures for inquiries may be listed within.

ASME B16.25-2017

Get more FREE standards from Standard Sharing Group and our chats

ISBN 978-0-7918-7189-8



9 7 8 0 7 9 1 8 7 1 8 9 8



J 0 1 3 1 7